

**25**<sup>+</sup>  
year  
1998-2023

**KeramControls**<sup>®</sup>  
启元控制

**KERAM (NANJING) ELECTRICAL EQUIPMENT CO., LTD.**

Factory : 7.Suite 701, East Tower of jin Run Intl Plaza, No.81,Nanxijiang Dong Street, Nanjing, China  
Sales Office : Room 1010-1011, Jinrun Building West Tower, Jianye District, Nanjing, China  
Tel : +86-25-8320 1426 Fax : +86-25-5282 1532  
Email: info@keramcontrols.com

Official Accounts Website



KeramControls<sup>®</sup> 启元控制

Product Catalogue



**KeramControls**<sup>®</sup>



Global Design Concept  
Reliable Quality Supplier

NON

2023

Product Catalogue

Sensor Technology



Sensor Technology

Twenty-five years of industry experience, organized staff team  
strict production process, advanced calibration equipment  
Strict factory standards, dedicated after-sales service



## A Message For Our Customer

From the initial establishment to the scale now, Keram control has gone through 25 years. Over the past 25 years, from simple manufacturing to independent research and development capabilities, we have been committed to the research and development of sensing field, such as pressure, flow, temperature and humidity, and have accumulated rich industry experience. In the process of constantly overcoming difficulties, we have achieved a qualitative leap from quantitative change. At present, it has a number of product patents and European CE, Rohs certificates, and has obtained ISO9001:2015 quality system certification.

The specialization, refinement and high cost performance of product manufacturing are the goals we are always pursuing, which makes us a high-quality supplier of many international brands.

**Keram Controls**  
**2023.3**

## Our History

Nanjing Qiyuan Controls & Equipment Co., Ltd. was found in 1998.

In 2005, the number of the employees increased to more than 50.

In 2006, its manufacturing base was moved to Huai An Industrial Development Zone.

Keram Controls has obtained the investment from Keram Group in 2009.

In 2014, business expands to electrical components and appliance, and changed its name to Keram (Nanjing) Electrical Equipment Co., Ltd.

## Our Values



**Customer First**



**Quality-oriented**



**Continue to innovate**



**Dedication**



**Integrity**



**Passions**

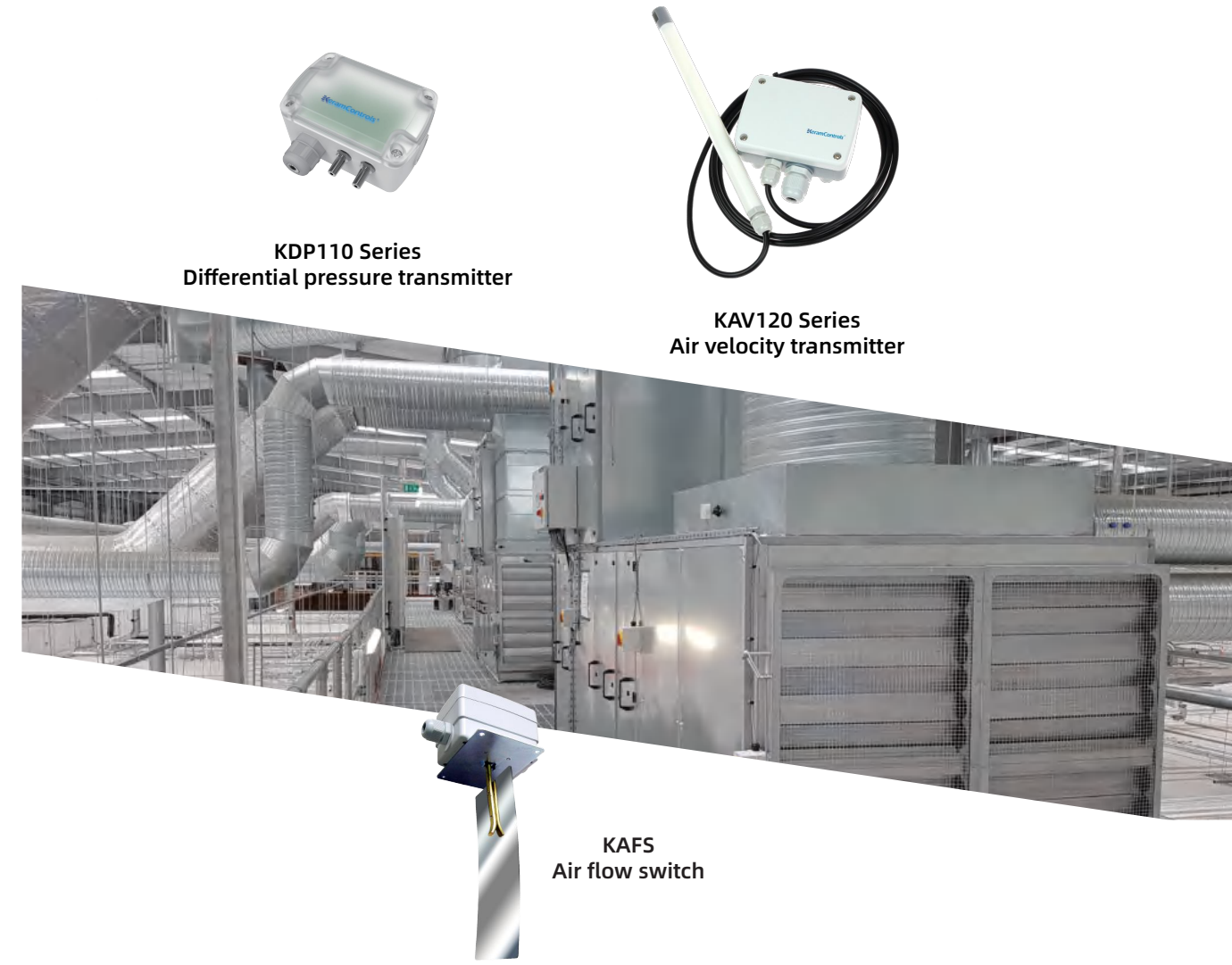
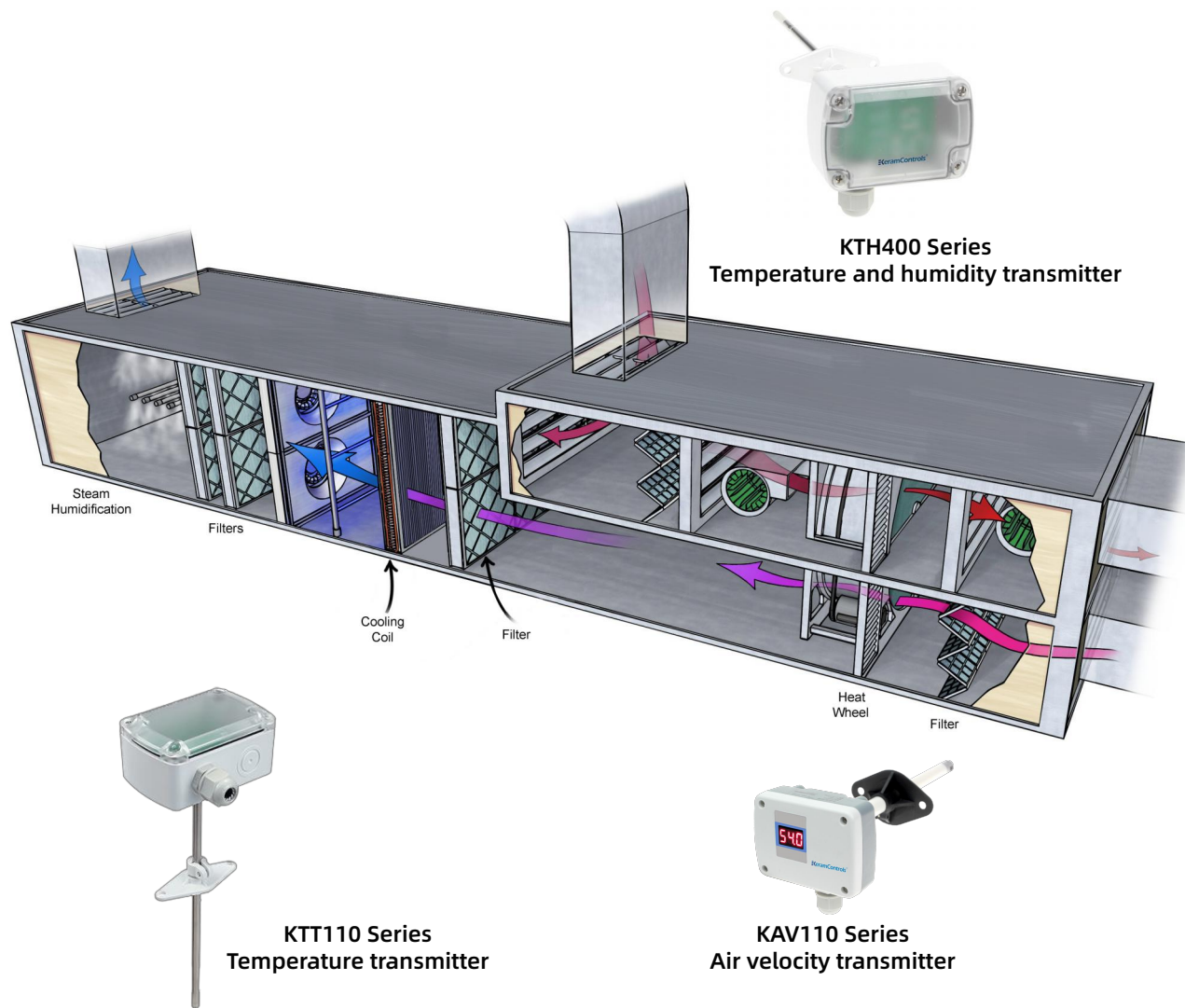

## APPLICATIONS Air handling units

The Air Handling Unit (AHU) is a centralized air handling system. It originated from a centralized hot air heating and ventilation system in which equipment is installed centrally and air is distributed through air ducts.

The basic centralized system is an all-air single-zone system, which generally includes fans, heaters, coolers, and filter components.

Keram Controls provides a variety of sensors and switches for monitoring air handling units to increase work efficiency and accuracy.

## APPLICATIONS Demand-controlled ventilation (DCV)

In crowded places or buildings, ventilation needs to be enhanced, in this case ventilation solutions are essential.

For example, schools, large shopping malls, stadiums, etc., maintaining good air quality in these important places can greatly improve comfort.

In addition to ensuring good air quality, on-demand controlled ventilation can also reduce energy consumption.

# PRODUCT CONTENTS



## PRESSURE CONTROLS



### Differential pressure transmitter

KDP110 Series	9-10
KDP210 Series	11-12
KLDP Series	13-14

### Pressure switch

Q Series single pressure switch	15-17
Q Series waterproof single pressure switch	18-19
Q830 Series dual pressure switch	20-21
QYD Series differential pressure switch	22-23
QYD Series waterproof differential pressure switch	24-25
KCL Series differential pressure switch	26-27
QAD Series differential pressure switch	28-29

## TEMPERATURE & HUMIDITY



KTH400 Series	31-32
KTH500 Series	33-34
KTH510 Series	35-36
KTH600 Series	37-39
KTH610 Series	40-42
HTP110 Series	43-44
HTP120 Series	45-46

## TEMPERATURE



### Temperature sensor

KTC110 cable type	48-49
KTC111 cable type	50-52
KTS100 wall mounted	53-54
KTS110 ductl mounted	55-58
KTS120 cable type	59-60
KTS130 clamp type	61-63
KTP110 immersion	63-67

### Temperature transmitter

KTT100 wall mounted	69-70
KTT110 ductl mounted	71-73
KTT120 cable type	74-75
KTT130 clamp type	76-78

## Wind speed & Volume



KAV110	80-81
KAV120	82-85



**KDP210 Series**  
Differential pressure transmitter



**KTH500 Series**  
Temperature & humidity transmitter



**KAQ CO2 Series**  
CO2 Transmitter

## APPLICATIONS Clean room

Designed to monitor pressure differences between rooms, KDP210 differential pressure transmitters measure the difference in pressure between the cleanroom and the outdoor air.

When equipment pressurization requires high precision and stability, KDP210 can measure very small pressure differences, so it is an excellent choice.

In addition to measuring pressure differences, it is important to measure the temperature and humidity in cleanrooms.

# PRODUCT CONTENTS

## FLOW CONTROL



### Air flow switch

KAFS 87-88

### Liquid flow switch

KWFS Series 89-90

KWFS (s) Series 91-92

JWFS Series 93-94

LQY Series 95-96

KFS1 Series 97-98

KFS2 Series 99-103

KMFS1 Series 104-107

KMFS2 Series 108-109

## AIR QUALITY



### CO2 transmitter

KAQ CO2 111-112

### All-in-one transmitter

KTHP100 differential pressure & temperature and humidity 113-115

## ACCESSORIES



### Flow

Pipe Tee 116

### Humidity

Filter 117

Flange 118

### Pressure

Pressure nipples 119

### Temperature

Immersion sleeve 120

Hose clamp 121

## CERTIFICATE



ISO 122

Patent certification CE 122

CE 123

## DATA

Temperature resistance table 124-126



## Pressure measurement equipment for all application accuracy needs

KeramControls pressure sensors cover all typical pressure measurement applications, from low pressure to high pressure measurement range, including gas and liquid pressure measurement.

## High Accuracy & Long-Term Stability

Optimal measuring components and advanced chips, strict production process control, detailed testing process, and advanced calibration equipment ensure high precision in the entire measurement range and long-term stable operation of the equipment.

# KDP110 Differential Pressure Transmitter



## Description

KDP110 differential pressure transmitter has the characteristics of high accuracy, ultra-low adjustable range and fast response. It is widely used in the clean rooms of electronic and pharmaceutical factories, as well as the automatic control system of commercial buildings, HVAC air conditioning processor system, medical centers and transportation hubs.

## Features

- Ranges from -25/+25Pa to -10000/+10000Pa (according to models)
- Auto zero manual calibration
- Voltage, current, digital signal output
- Standard accuracy <math>\pm 1\%</math> FS
- IP65 house protection

## Application

- HVAC system
- Pharmaceutical clean rooms
- Electronic clean rooms
- Medical clean rooms
- Commercial buildings
- Public transport hub

## Technical Data

Model	KDP110
Measurement units	Pa, mmH <sub>2</sub> O, inWG, mmHG, kPa, mbar
Accuracy	<math>\pm 1\%</math> FS@-5 to +65°C
Response time	0.5s
Repeatbality	$\pm 0.01\%$ at FS/year
Resolution	0.1 Pa; 0.1 mmH <sub>2</sub> O; 0.01mbar; 0.01mmHG
Media	Air and neutral gases
Operating temperature	-20 ... +70°C
Storage temperature	-40 ... +60°C
Power consumption	< 1.5W
Tolerated overpressure	x15
Power Supply	16~30VAC/DC (3 wire) / 18~30VDC (2 wire)
Output	4-20mA (2 wire)
	4-20mA (3 wire)
	0~5V/0~10V (3 wire)
	RS-485
	Customized
Auto zero	Manual calibration
Housing material	PC&ABS, UL94V-0
Protection class	IP65/NEMA4
Cable Gland	M16*1.5

## Dimensions (mm)

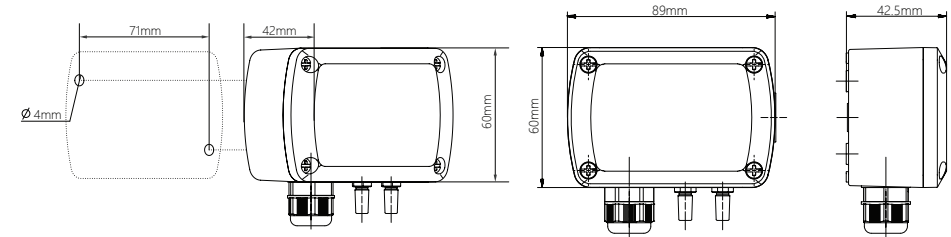

## Manual Zero-point Correction

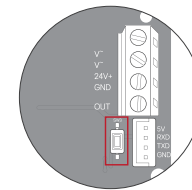

In normal operation zero point correction should be executed every 12 months. For executing zero point correction the power supply must be connected one hour before.

- Release both connection tubes from the pressure
- Terminals + and - Press and hold the button for 3 seconds.
- Reinstall the connection tubes

## Accessories(OPTIONAL)

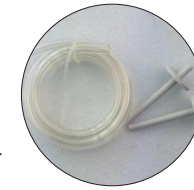

Pressure connection set:  
2m PVC hose  
with 2 ABS pressure  
connection nipples.

## Ordering Guide

Model	Wiring	Range	Output	Product number
KDP110-1-E	2-wire	0 ... 25Pa 0 ... 50Pa	4-20mA	01020640020100
KDP110-1-F	3-wire	0 ... 75Pa 0 ... 100Pa	4-20mA	01020640020200
KDP110-1-G	3-wire	-25 ... +25Pa -50 ... +50Pa	0-10V	01020640020300
KDP110-1-H	4-wire	-75 ... +75Pa -100 ... +100Pa	RS-485	01020640020400
KDP110-2-E	2-wire	0 ... 250Pa 0 ... 500Pa	4-20mA	01020010020100
KDP110-2-F	3-wire	0 ... 750Pa 0 ... 1000Pa	4-20mA	01020010020200
KDP110-2-G	3-wire	-250 ... +250Pa -500 ... +500Pa	0-10V	01020010020300
KDP110-2-H	4-wire	-750 ... +750Pa -1000 ... +1000Pa	RS-485	01020010020400
KDP110-3-E	2-wire	0 ... 500Pa 0 ... 1000Pa	4-20mA	01020020020100
KDP110-3-F	3-wire	0 ... 1500Pa 0 ... 2000Pa	4-20mA	01020020020200
KDP110-3-G	3-wire	-500 ... +500Pa -750 ... +750Pa	0-10V	01020020020300
KDP110-3-H	4-wire	-1000 ... +1000Pa -2000 ... +2000Pa	RS-485	01020020020400
KDP110-4-E	2-wire	0 ... 2500Pa 0 ... 5000Pa	4-20mA	01020030020100
KDP110-4-F	3-wire	0 ... 7500Pa 0 ... 10000Pa	4-20mA	01020030020200
KDP110-4-G	3-wire	-2500 ... +2500Pa -5000 ... +5000Pa	0-10V	01020030020300
KDP110-4-H	4-wire	-7500...+7500Pa -10000...+10000Pa	RS-485	01020030020400

压力换算表 Pressure Conversion Table

	Pa	mbar	mmH <sub>2</sub> O	mmHg	lbf/in (psi)
1Pa=	1	0.01	0.102	0.007501	0.000145
1mbar=	100	1	10.2	0.7501	0.0145
1mmH <sub>2</sub> O=	9.807	0.09807	1	0.07356	1.422
1mmHg=	133.3	1.333	13.66	1	0.01934
1lbf/in (psi)=	6895	68.95	0.7031	51.72	1

# KDP210 Differential Pressure Transmitter



## Features

- Ranges from -25/+25Pa to -10000/+10000Pa (according to models)
- Auto zero manual calibration
- Voltage, current, digital signal output
- Backlight LCD display
- Standard accuracy <math>\pm 1\%</math> FS
- Adjusting measurement time by setting button
- External mounting holes
- IP65 house protection

Mounting with closed cover  
Easy & fast mounting

## Description

KDP210 differential pressure transmitter has high precision, ultra-low & adjustable range, fast response characteristics, widely used in clean electronics and pharmaceutical factories, as well as large commercial buildings, medical centers and transportation hub.

## Technical Data

Model	KDP210
Measurement units	Pa, mmH <sub>2</sub> O, inWG, mmHG, mbar
Accuracy	<math>\pm 1\%</math> FS@-5 to +65°C
Response time	0.5s
Repeatability	$\pm 0.01\%$ at FS/year
Resolution	0.1 Pa; 0.1 mmH <sub>2</sub> O; 0.01mbar; 0.01mmHG
Media	Air and neutral gases
Operating temperature	-20 ... +70°C
Storage temperature	-40 ... +60°C
Power consumption	< 3W
Tolerated overpressure	x15
Power Supply	16~30VAC/DC (3 wire) / 18~30VDC (2 wire)
Output	4-20mA (2 wire)
	4-20mA (3 wire)
	0~5V/0~10V (3 wire)
	RS-485
	Customized
Auto zero	Manual calibration
Housing material	PC&ABS, UL94V-0
Protection class	IP65/NEMA4
Display	Backlight LCD display
Cable Gland	M16*1.5

## Dimensions (mm)

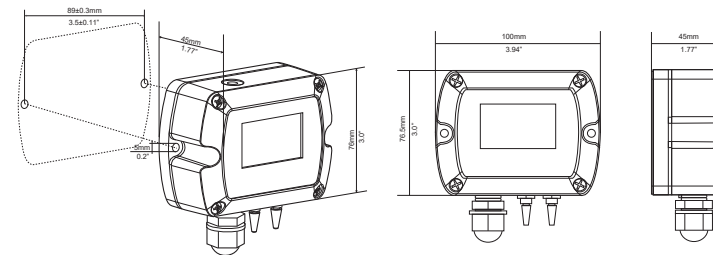

## Ordering Guide

● Backlight LCD ■ No Backlight LCD × No display

Model	Wiring	Range	Display	Output	Product number
KDP210-1-D-E	2 wire	0 ... 25Pa 0 ... 50Pa	■	4-20mA	01010640010100
KDP210-1-E			×		01010640020100
KDP210-1-D-F	3 wire	0 ... 75Pa 0 ... 100Pa	●	4-20mA	01010640010200
KDP210-1-F			×		01010640020200
KDP210-1-D-G	3 wire	-25 ... +25Pa -50 ... +50Pa	●	0-10V	01010640010300
KDP210-1-G			×		01010640020300
KDP210-1-D-H	4 wire	-75 ... +75Pa -100 ... +100Pa	●	RS-485	01010640010400
KDP210-1-H			×		01010640020400
KDP210-2-D-E	2 wire	0 ... 250Pa 0 ... 500Pa	■	4-20mA	10100100101000
KDP210-2-E			×		01010010020100
KDP210-2-D-F	3 wire	0 ... 750Pa 0 ... 1000Pa	●	4-20mA	01010010010200
KDP210-2-F			×		01010010020200
KDP210-2-D-G	3 wire	-250 ... +250Pa -500 ... +500Pa	●	0-10V	01010010010300
KDP210-2-G			×		01010010020300
KDP210-2-D-H	4 wire	-750 ... +750Pa -1000 ... +1000Pa	●	RS-485	01010010010300
KDP210-2-H			×		01010010020400
KDP210-3-D-E	2 wire	0 ... 500Pa 0 ... 1000Pa	■	4-20mA	01010020010100
KDP210-3-E			×		01010020020100
KDP210-3-D-F	3 wire	0 ... 1500Pa 0 ... 2000Pa	●	4-20mA	01010020010200
KDP210-3-F			×		01010020020200
KDP210-3-D-G	3 wire	-500 ... +500Pa -750 ... +750Pa	●	0-10V	01010020010300
KDP210-3-G			×		01010020020300
KDP210-3-D-H	4 wire	-1000 ... +1000Pa -2000 ... +2000Pa	●	RS-485	01010020010400
KDP210-3-H			×		01010020020400
KDP210-4-D-E	2 wire	0 ... 2500Pa 0 ... 5000Pa	■	4-20mA	01010030010100
KDP210-4-E			×		01010030020100
KDP210-4-D-F	3 wire	0 ... 7500Pa 0 ... 10000Pa	●	4-20mA	01010030010200
KDP210-4-F			×		01010030020200
KDP210-4-D-G	3 wire	-2500 ... +2500Pa -5000 ... +5000Pa	●	0-10V	01010030010300
KDP210-4-G			×		01010030020300
KDP210-4-D-H	4 wire	-7500...+7500Pa -10000...+10000Pa	●	RS-485	01010030010400
KDP210-4-H			×		01010030020400

## Pressure Conversion Table

	Pa	mbar	mmH <sub>2</sub> O	mmHg	lbf/in (psi)
1Pa=	1	0.01	0.102	0.007501	0.000145
1mbar=	100	1	10.2	0.7501	0.0145
1mmH <sub>2</sub> O=	9.807	0.09807	1	0.07356	1.422
1mmHg=	133.3	1.333	13.66	1	0.01934
1lbf/in (psi)=	6895	68.95	0.7031	51.72	1



### Description

KLDP series differential pressure transmitter use a piezo-resistive sensor and incorporate zero and span adjustment. They are ideal for use in areas requiring exact pressure measurement, 0.25% high accuracy, low hysteresis and long term stability. For all applications where air, oil or water are to be monitored.

### Application

KLDP series pressure transmitters are suitable for measuring pressure in all applications where air, oil or water are to be monitored. Also compatible with refrigerants. They are suitable for all kind of tasks in air-conditioning, heating and water systems.

### Features

- (according to models) Voltage, current output
- Standard accuracy  $< \pm 0.25\%$  FS
- IP65
- Repeatability 0.1% FS/year typical
- Temperature range -20 to +80
- Pressure connection 1/8" BSP female brass
- Ranges from 0 to 35 mbar to 0 to 17 bar
- Line pressure 34 Bar G

### Technical Data

Model	KLDP
Measurement units	mbar
Accuracy	$< \pm 0.25\%$ FS
Response time	1s
Repeatbality	$\pm 0.1\%$ at FS/year
Media	Air, oil or water
Operating temperature	-20 to +80°C
Storage temperature	-40 to +80°C
Tolerated overpressure	x15
Power Supply	24Vac/dc
Output	4-20mA (2 wire) 0-5/0-10VDC (3 wire)
Housing material	Brass/Stainless steel
Protection class	IP65/NEMA4

### Dimensions (mm)

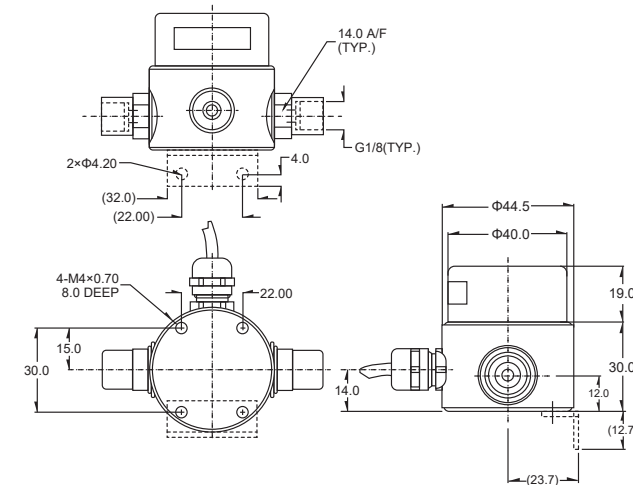

### Ordering Guide

Model	Wiring	Output	Material	Product number
KLDP-1EB	0-35mbar	4-20mA	Brass	01080250080100
KLDP-2EB	0-70mbar			01080260080100
KLDP-3EB	0-350mbar			01080270080100
KLDP-4EB	0-1bar			01080280080100
KLDP-5EB	0-2bar			01080290080100
KLDP-6EB	0-7bar			01080300080100
KLDP-7EB	0-17bar			01080310080100
KLDP-1ES	0-35mbar		Stainless steel	01080250090100
KLDP-2ES	0-70mbar			01080260090100
KLDP-3ES	0-350mbar			01080270090100
KLDP-4ES	0-1bar			01080280090100
KLDP-5ES	0-2bar			01080290090100
KLDP-6ES	0-7bar			01080300090100
KLDP-7ES	0-17bar			01080310090100
KLDP-1GB	0-35mbar	0-10V	Brass	01080250080300
KLDP-2GB	0-70mbar			01080260080300
KLDP-3GB	0-350mbar			01080270080300
KLDP-4GB	0-1bar			01080280080300
KLDP-5GB	0-2bar			01080290080300
KLDP-6GB	0-7bar			01080300080300
KLDP-7GB	0-17bar			01080310080300
KLDP-1GS	0-35mbar		Stainless steel	01080250090300
KLDP-2GS	0-70mbar			01080260090300
KLDP-3GS	0-350mbar			01080270090300
KLDP-4GS	0-1bar			01080280090300
KLDP-5GS	0-2bar			01080290090300
KLDP-6GS	0-7bar			01080300090300
KLDP-7GS	0-17bar			01080310090300



# Q Series Single Pressure Switch



## Description

- Q series single pressure controls can be not only used in fluoridated refrigerant, but also in the air and liquid(allowed liquid temp. -20 to 120 )
- Ambient working temp: -20 ~70
- Adjustable range and differential settings
- Renovated SPDT micro-switch ensures the reliable switch function
- Flexible mounting bracket suits various kinds of application
- Upper lid is optional (IP44)
- Various connections are available on request
- Automatic and manual reset version
- The material of bellows is copper and pressure interface is brass
- Several models available in drip-proof enclosure for marine applications or in explosion-proof enclosure for special applications
- CE approval

## Model Specification

Model	Range (bar)		Differential(bar)		Factory Setting(bar)		Max. bellows pressure ( bar )
	Min	Max	Min	Max	OFF	ON	
Q3	-0.5	3	0.35	1.5	2	1	16.5
Q6	-0.5	6	0.6	4	3	2	16.5
Q6M	-0.5	6	≤1		3	Manual Reset	16.5
Q10	1	10	1	3	6	5	16.5
Q16	5	16	1	4	10	8	33
Q20	5	20	2	5	16	3	33
Q30D	5	30	3	10	20	15	33
Q30	6	30	3-5(Fixed)		20	15-17	33
Q30M	6	30	≤5		20	Manual Reset	33

Note : Calibration unit on scale plate with "bar" & "psig" , it also could be revised into "Mpa" & "kgf/cm<sup>2</sup>" according to customer's requirements. Connections could have selections as British Flare (E), solder (C) and capillary (S).

## Dimensions (mm)

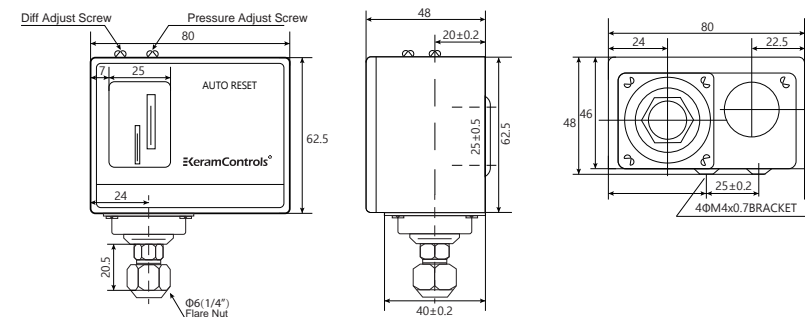

## Electric Rating

Rated Amps(A)	Rated Voltage(V)	125V AC	250V AC
Non-Inductive Current		20A	10A
Inductive Current	Full Load Current	15A	8A
	Locked Roter	72A	

## Electric Wiring

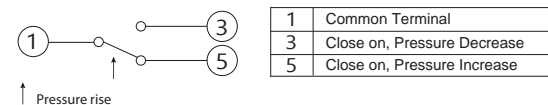

## Connection & Installation

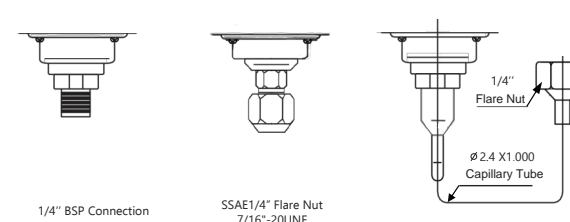

## Mounting Plate

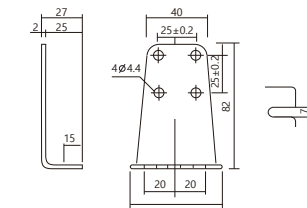

# Q Series Single Pressure Switch

# Q Series Waterproof Single Pressure Switch

## Ordering Guide

●:SAE 1/4" Flare Nut 7/16" -20UNF ■:1/4" BSP ▲:1/4" Flare Nut

Model	Pressure range(bar)	Connector	Reset	Product number
Q3-SAE	- 0.5-3	●	Auto Reset	01030040030600
Q3-BSP		■		01030040040600
Q3-Flare		▲		01030040050600
Q6-SAE	- 0.5-6	●	Manual Reset	01030050030600
Q6-BSP		■		01030050040600
Q6-Flare		▲		01030050050600
Q6M-SAE	- 0.5-6	●	Manual Reset	01030050030500
Q6M-BSP		■		01030050040500
Q6M-Flare		▲		01030050050500
Q10-SAE	1-10	●	Auto Reset	01030060030600
Q10-BSP		■		01030060430600
Q10-Flare		▲		01030060030600
Q16-SAE	5-16	●	Auto Reset	01030070030600
Q16-BSP		■		01030070040600
Q16-Flare		▲		01030070030600
Q20-SAE	5-20	●	Auto Reset	01030080030600
Q20-BSP		■		01030080040600
Q20-Flare		▲		01030080030600
Q30D-SAE	5-30	●	Manual Reset	01030090030600
Q30D-BSP		■		01030090040600
Q30D-Flare		▲		01030090030600
Q30M-SAE	6-30	●	Manual Reset	01030090030500
Q30M-BSP		■		01030090040500
Q30M-Flare		▲		01030090030500
Q30-SAE	6-30	●	Auto Reset	01030100030600
Q30-BSP		■		01030100040600
Q30-Flare		▲		01030100050600



## Description

- Q series single pressure controls can be not only used in fluoridated refrigerant, but also in the air and liquid(allowed liquid temp. -20 to 120 )
- Ambient working temp: -20 ~70
- Adjustable range and differential settings
- Renovated SPDT micro-switch ensures the reliable switch function
- Flexible mounting bracket suits various kids of application
- Upper lid is optional (IP65)
- Various connections are available on request
- Automatic and manual reset version
- The material of bellows is copper and pressure interface is brass
- Several models available in drip-proof enclosure for marine applications or in explosion-proof enclosure for special applications
- CE approval

## Model Specification

Model	Range(bar)		Differential(bar)		Factory Setting(bar)		Max. bellows pressure ( bar )
	MIN	MAX	MIN	MAX	OFF	ON	
Q3(w)	-0.5	3	0.35	1.5	2	1	16.5
Q6(w)	-0.5	6	0.6	4	3	2	16.5
Q6M(w)	-0.5	6	≤1		3	Manual Reset	16.5
Q10(w)	1	10	1	3	6	5	16.5
Q16(w)	5	16	1	4	10	8	33
Q20(w)	5	20	2	5	16	3	33
Q30D(w)	5	30	3	10	20	15	33
Q30(w)	6	30	3-5(Fixed)		20	15-17	33
Q30M(w)	6	30	≤5		20	Manual Reset	33

Note :

Calibration unit on scale plate with "bar" & "psig" , it also could be revised into "Mpa" & "kgf/cm<sup>2</sup>" according to customer's requirements. Connections could have selections as British Flare (E), solder (C)and capillary (S).

## Dimensions (mm)

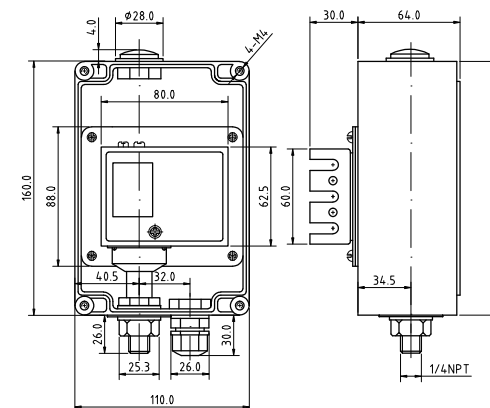

# Q Series Waterproof Single Pressure Switch

# Q830 Series Dual Pressure Switch

## Electric Rating

Rated Amps(A)		Rated Voltage(V)		125V AC	250V AC
Non-Inductive Current				20A	10A
Inductive Current	Full Load Current			15A	8A
	Locked Roter			72A	

## Electric Wiring

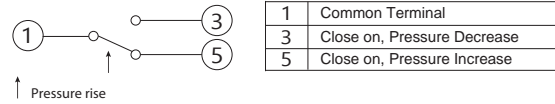

## Connection & Installation

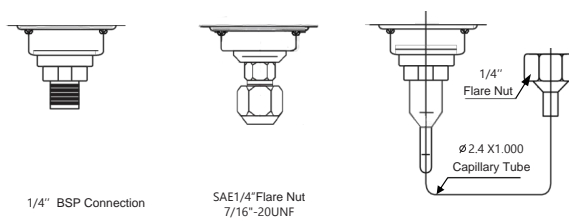

## Mounting Plate

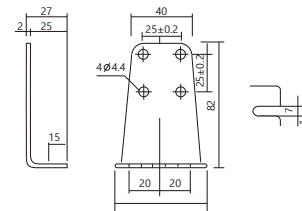

## Ordering Guide

●:SAE 1/4" Flare Nut 7/16" -20UNF ■:1/4" BSP ▲:1/4" Flare Nut

Model	Pressure range(bar)	Connector	Reset	Product number	
Q3(W)-SAE	- 0.5-3	●	Auto Reset	01420040030600	
Q3(W)-BSP		■		01420040040600	
Q3(W)-Flare		▲		01420040050600	
Q6(W)-SAE	- 0.5-6	●		Manual Reset	01420050030600
Q6(W)-BSP		■			01420050040600
Q6(W)-Flare		▲			01420050050600
Q6M(W)-SAE		●	01420050030500		
Q6M(W)-BSP		■	01420050040500		
Q6M(W)-Flare		▲	01420050050500		
Q10(W)-SAE	1-10	●	Auto Reset	01420060030600	
Q10(W)-BSP		■		01420060430600	
Q10(W)-Flare		▲		01420060030600	
Q16(W)-SAE	5-16	●		Auto Reset	01420070030600
Q16(W)-BSP		■			01420070040600
Q16(W)-Flare		▲			01420070030600
Q20(W)-SAE	5-20	●	Auto Reset		01420080030600
Q20(W)-BSP		■			01420080040600
Q20(W)-Flare		▲			01420080030600
Q30D(W)-SAE	5-30	●		Auto Reset	01420090030600
Q30D(W)-BSP		■			01420090040600
Q30D(W)-Flare		▲			01420090030600
Q30M(W)-SAE	6-30	●	Manual Reset		01420090030500
Q30M(W)-BSP		■			01420090040500
Q30M(W)-Flare		▲			01420090030500
Q30(W)-SAE		●	Auto Reset	01420100030600	
Q30(W)-BSP		■		01420100040600	
Q30(W)-Flare		▲		01420100050600	



## Description

- Q830 series dual pressure controls can be not only used in fluoridated refrigerant, but also in the air and liquid (allowed liquid temp. -20 to 120 )
- Ambient working temp: -20 ~70
- Adjustable range and differential settings
- Renovated SPDT micro-switch ensures the reliable switch function
- Flexible mounting bracket suits various kinds of application
- Upper lid is optional (IP44)
- Various connections are available on request
- Automatic and manual reset version
- The material of bellows is copper and pressure interface is brass
- CE approval

## Model Specification

Model	Low pressure (bar)		High pressure (bar)		Reset form(bar)		Factory setting(bar)			
	Pressure adjust range	Differential	Pressure adjust range	Differential	Low pressure	High pressure	Low pressure		High pressure	
							OFF	ON	OFF	ON
Q830	-0.5~6	0.6~4	8~30	3~5(Fixed)	Auto	Auto	3	2	20	15
Q830HM	-0.5~6	0.6~4	8~30	<5	Auto	Auto	3	2	20	Manual Reset
Q830HLM	-0.5~6	≤1	8~30	<5	Manual	Manual		Manual	20	Manual Reset

## Dimensions (mm)

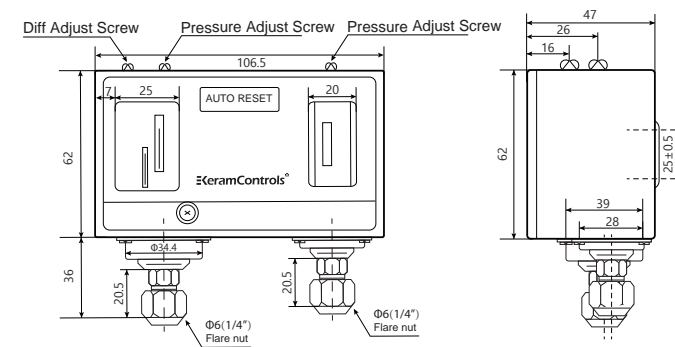

# Q830 Series Dual Pressure Switch

# QYD Series Differential Pressure Switch

## Electric Rating

Rated Amps(A)	Rated Voltage(V)	power Factor (Cos Φ)	125/250V AC
Non-Inductive Current		1	12
Inductive Current	Full Load Current	0.75	12
	Locked Roter	0.45	72

## Electric Wiring

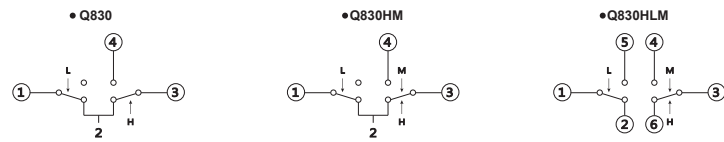

## Connection & Installation

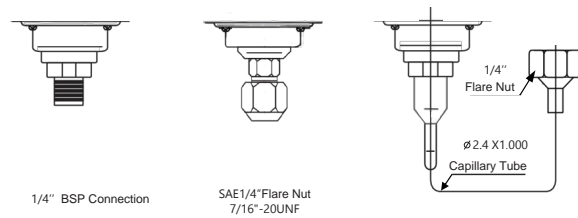

## Mounting Plate

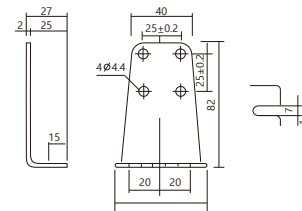

## Ordering Guide

●:SAE 1/4" Flare Nut 7/16" -20UNF ■:1/4" BSP ▲:1/4" Flare Nut

Model	Connector	Reset	Product number
Q830-SAE	●	AUTO	01030110030600
Q830-BSP	■	Low pressure auto, high pressure manual	01030110040600
Q830-Flare	▲	Low pressure manual, high pressure manual	01030110050600
Q830HM-SAE	●	AUTO	01030110030700
Q830HM-BSP	■	Low pressure auto, high pressure manual	01030110040700
Q830HM-Flare	▲	Low pressure manual, high pressure manual	01030110030700
Q830HLM-SAE	●	AUTO	01030110030800
Q830HLM-BSP	■	Low pressure auto, high pressure manual	01030110040800
Q830HLM-Flare	▲	Low pressure manual, high pressure manual	01030110050800



## Description

- QYD series differential pressure switch is designed to prove flow through pumps Renovated SPDT micro -switch ensure the reliable switch function
- Ambient working temp: -20 ~70
- Used in fluoridated refrigerant, but also in air and liquid(-20 to 120 )
- Flexible mounting bracket suits various kinds of application
- Various connections are available on request
- IP33 rating
- CE approval

## Model Specification

Model	Differential(Bar)		Factory setting(bar)	Max working pressure(Bar)
	Min	Max		
QYD2C	0.5	2	0.5	12
QYD4C	0.5	3.5	1	12
QYD4CH	0.5	3.5	1	30
QYD6CH	1	6	6	30
QYD4C/B	0.3	4	0.3	17

## Dimensions (mm)

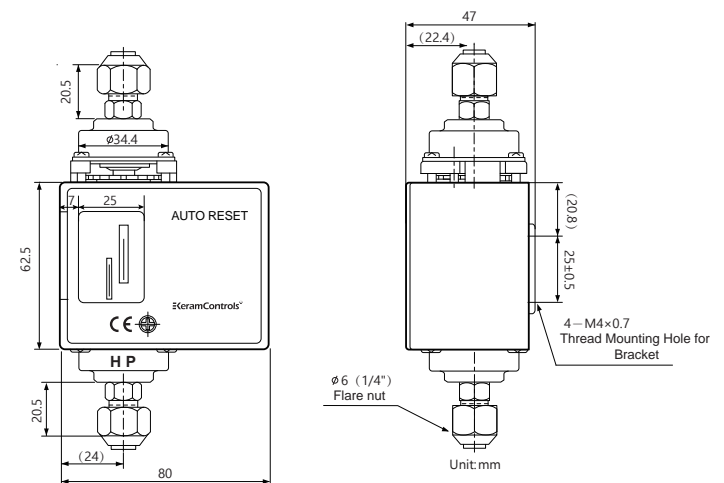

# QYD Series Differential Pressure Switch

# QYD Series Water Differential Pressure Switch

## Electric Rating

Rated Amps(A)		Rated Voltage(V)	125V AC	250V AC
Non-Inductive Current			20A	10A
Inductive Current	Full Load Current		15A	8A
	Locked Roter		72A	

## Electric Wiring

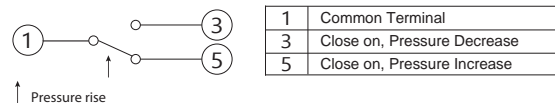

## Connection & Installation

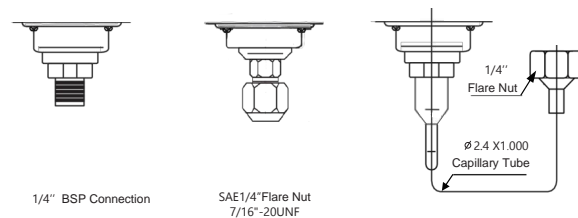

## Mounting Plate

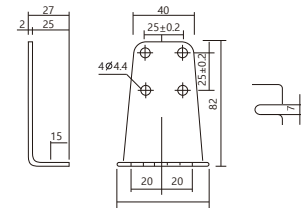

## Operating Instruction

1. The new outer cover, two fingers pinch both sides of the plastic lid, open the outer cover can be pumped out;
2. To be installed in the pipe, must use two wrenches and twist tight;
3. Do not install the controller over electric rating of the device.

## Ordering Guide

●:SAE 1/4" Flare Nut 7/16" -20UNF ■:1/4" BSP ▲:1/4" Flare Nut

Model	Max differential pressure (bar)	Min differential pressure	Connector	Product number
QYD2C-SAE	0.5	2	●	01040120030900
QYD2C-BSP			■	01040120040900
QYD2C-Flare			▲	01040120050900
QYD4C-SAE	0.5	3.5	●	01040130030900
QYD4C-BSP			■	01040130040900
QYD4C-Flare			▲	01040130050900
QYD4CH-SAE	1	6	●	01040130031000
QYD4CH-BSP			■	01040130041000
QYD4CH-Flare			▲	01040130051000
QYD6CH-SAE	1	6	●	01040050031000
QYD6CH-BSP			■	01040050041000
QYD6CH-Flare			▲	01040050051000
QYD4C/B-SAE	0.3	4	●	01040140031100
QYD4C/B-BSP			■	01040140041100
QYD4C/B-Flare			▲	01040140051100

## Description

- QYD series waterproof differential pressure switch is designed to prove flow through pumps Renovated
- Ambient working temp: -20 ~70
- SPDT micro-switch ensure the reliable switch function
- Used in fluoridated refrigerant, but also in air and liquid(-20 to 120 )
- Flexible mounting bracket suits various kinds of application
- Various connections are available on request
- IP65
- CE approval

## Model Specification

Model	Differential(Bar)		Factory setting(bar)	Max working pressure(Bar)
	Min	Max		
QYD2C(W)	0.5	2	0.5	12
QYD4C(W)	0.5	3.5	1	12
QYD4CH(W)	0.5	3.5	1	30
QYD6CH(W)	1	6	6	30
QYD4C/B(W)	0.3	4	0.3	17

## Dimensions (mm)

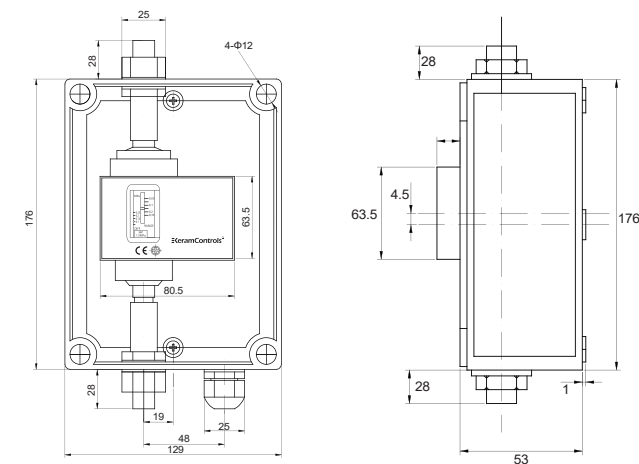

# QYD Series Water Differential Pressure Switch

# KCL Series Differential Pressure Switch

## Electric Rating

Rated Amps(A)		Rated Voltage(V)	125V AC	250V AC
Non-Inductive Current			20A	10A
Inductive Current	Full Load Current		15A	8A
	Locked Roter		72A	

## Electric Wiring

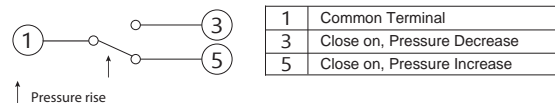

## Connection & Installation

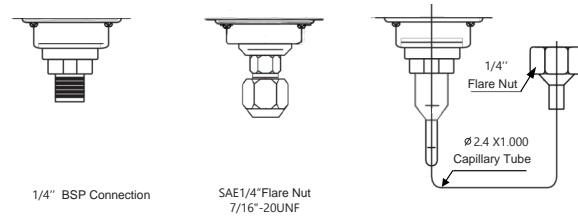

## Mounting Plate

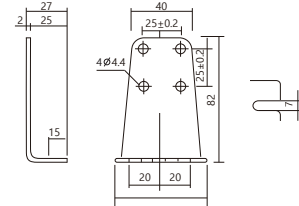

## Operating Instruction

1. The new outer cover, two fingers pinch both sides of the plastic lid, open the outer cover can be pumped out;
2. To be installed in the pipe, must use two wrenches and twist tight;
3. Do not install the controller over electric rating of the device.

## Ordering Guide

●:SAE 1/4" Flare Nut 7/16" -20UNF ■:1/4" BSP ▲:1/4" Flare Nut

Model	Max differential pressure (bar)	Min differential pressure	Connector	Product number
QYD2C(W)-SAE	0.5	2	●	01050120030900
QYD2C(W)-BSP			■	01050120040900
QYD2C(W)-Flare			▲	01050120050900
QYD4C(W)-SAE	0.5	3.5	●	01050130030900
QYD4C(W)-BSP			■	01050130040900
QYD4C(W)-Flare			▲	01050130050900
QYD4CH(W)-SAE	0.5	3.5	●	01050130031000
QYD4CH(W)-BSP			■	01050130041000
QYD4CH(W)-Flare			▲	01050130051000
QYD6CH(W)-SAE	1	6	●	01050050031000
QYD6CH(W)-BSP			■	01050050041000
QYD6CH(W)-Flare			▲	01050050051000
QYD4C(B(W)-SAE	0.3	4	●	01050140031100
QYD4C(B(W)-BSP			■	01050140041100
QYD4C(B(W)-Flare			▲	01050140051100



## Description

KCL series differential pressure switch is used to monitor the pressure difference of neutral and slightly aggressive liquid and gases. It is applied to monitor pump status, boiler, flow, and filter condition. It will send the signal when the flow or pressure falls or rises to an alarm condition. The special design makes it easy for installation and adjusting the switching point.

## Installation

- Make sure that the maximum pressure of DPS is higher than that of the pressure to be applied P1 is the high pressure side and P2 is the lower pressure side, it can't be fit reversely.
- Make sure that the electrical supply is isolated before removing the cover.
- Make sure the DPS electrical switch is of the correct rating.
- Make sure the terminals are correctly connected and the DPS is correctly earthed.
- Make sure the ambient and process temperature acting on the DPS should be within the -10 to 85 °C.
- Make sure that DPS is installed in a place with no vibration.
- For monitoring the pressure of liquid, DPS has to be installed horizontally to make sure the accuracy of measurement will not be effected by gravity.
- Make sure there has no sediments go into the sensor.
- Make sure there are no valves between sensing points.
- Adjusting switching point with the screw driver by the adjusting screw, test the whole system.

## Features

- High over pressure safety margin to 20 bar
- Adjustable mounting bracket
- Switching point is easy to be adjusted with adjustable screw
- Enclosure rating IP54
- CE approval

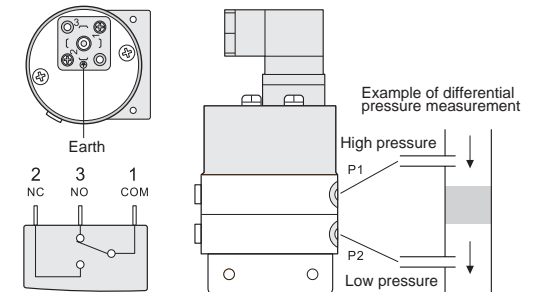

## Dimensions (mm)

Model	No.	KCL250 KCL1000	KCL4000
A		Φ29.0	Φ40.5
B		18.5	31.5
C		378	43.0
D		76.0	81.0
E		18.8	21.5
F		133.5	139.0

# KCL Series Differential Pressure Switch

# QAD Series Pressure Switch

## Dimensions (mm)

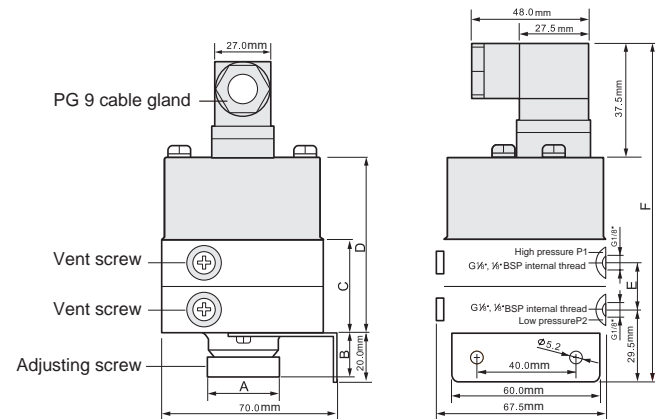

## Technical Data

Model	Pressure range	Hysteresis
KCL250	40 to 250 mbar	25 mbar
KCL1000	0.07 to 1 bar	50 mbar
KCL4000	0.2 to 4 bar	100 mbar

<b>Max working pressure</b>		20 bar
<b>Cable gland</b>		PG 9 thread (female in body)
<b>Life</b>		SPDT micro-switch with a rating of 5A at 250V AC
<b>Connect</b>		> 10 <sup>6</sup> switching cycles
<b>Material</b>	<b>Body</b>	Brass
	<b>Cover</b>	Steel with power painting
	<b>Diaphragm</b>	EPDM
<b>Pressure connection</b>		G1/8"(DIN 259), 1/8" BSP female thread, (P1>P2)Enclosure
<b>Protection class</b>		IP54
<b>Operating temperature</b>		-10 to 85°C
<b>Dimensions(H*L*W)</b>		133.5x675x67.5mm, 139x675x67.5mm
<b>Weight</b>		1100g, 1320g

## Ordering Guide

Model	Pressure range	Product number
KCL250	40 ~ 250 mbar	01060150070000
KCL1000	0.07 ~ 1bar	01060160070000
KCL4000	0.2 ~ 4 bar	01060170070000

## Technical Data

<b>Model</b>	<b>QAD</b>
<b>Media</b>	Air, non-combustible and non-aggressive gasses
<b>Max operating pressure</b>	10kPa
<b>Mounting position</b>	Diaphragm in any vertical plane
<b>Protection class</b>	IP54 (with cover)
<b>Operating temperature</b>	-40 ~85
<b>Connect</b>	SPDT
<b>Electric Rating</b>	Resistance: Initial: < 50 milliohms; Current 1.5A resistive (0.4A inductive) 250v
<b>Electrical connections</b>	6.3x0.8 blade 46244 or screw terminals
<b>Material</b>	Housing : ABS
	Duct connectors : ABS
	Membrane: Silicone
	Cable sleeve: PVC
<b>Weight</b>	0.15kg (0.35kg with flexible pipe)
<b>Connection</b>	6.0mm Dia. for tube connection
<b>Certificate</b>	UL, CE, RoHS

## Dimensions (mm)

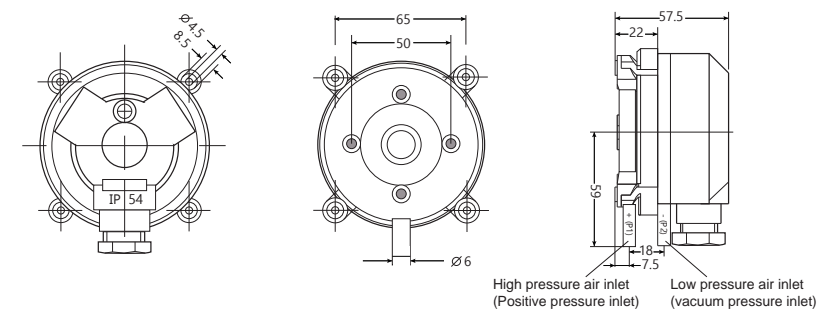

## Description

QAD series air pressure controls is used to sense tiny pressure change and widely used to control the flow of aerator, to monitor fan and air conditioner. It is also suitable for over heating protection and frost protection in industrial



# QAD Series Pressure Switch

## Installation Connection

QAD series air pressure controls is factory-calibrated for vertical position. If installed horizontally, this will affect the switching point as following:

- with cover facing upwards, switching point is 15Pa higher than scale;
- with cover facing downwards, switching point is 15Pa lower than scale.

Note:

Do not install upside down with trip pressures of less than 50pa !

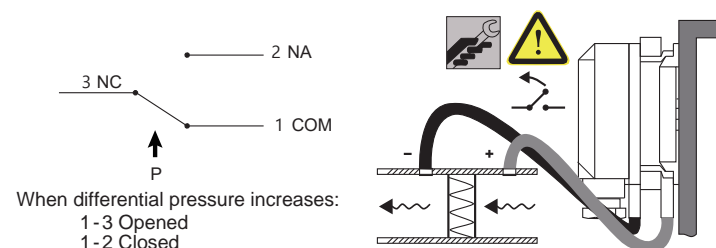

## Product Range

Model	Pressure range	Differential	Tolerance
QAD-1	20-200Pa	10Pa	±15%
QAD-2	30-300Pa	10Pa	±15%
QAD-3	40-400Pa	20Pa	±15%
QAD-4	50-500Pa	20Pa	±15%
QAD-5	200-1000Pa	100Pa	±15%
QAD-6	500-2500Pa	150Pa	±15%
QAD-7	1000-5000Pa	250Pa	±15%

The performances stated in this sheet can be modified without any prior notice due to design improvements.

## Ordering Guide

Model	Pressure range	Product Number
QAD-1	20-200Pa	01070180000000
QAD-2	30-300Pa	01070190000000
QAD-3	40-400Pa	01070200000000
QAD-4	50-500Pa	01070210000000
QAD-5	200-1000Pa	01070220000000
QAD-6	500-2500Pa	01070230000000
QAD-7	1000-5000Pa	01070240000000

## Stable measurement under harsh environmental conditions

Keram Controls humidity and temperature transmitter include models for HVAC applications of higher requirements, such as pharmaceuticals, clean rooms, and the food industry. Even in harsh environments, the sensor can guarantee long-term stable operation.

## High precision & Long-term stability

Optimal measuring components and advanced chips, strict production process control, detailed testing process, and advanced calibration equipment ensure high precision and longterm stable operation of the equipment in the entire measurement range

**KeramControls®**





### Description

KTH400 series economical temperature and humidity transmitters are divided into two installation methods: wall-mounted and duct-mounted. Among them, the newly designed shell can minimize installation costs and provide excellent pollution and condensation protection; the output signal has voltage or current and RS-485 signals are available.

### Application

- HVAC system
- Greenhouse
- Food transportation
- Cold storage and refrigeration
- Clean room environment monitoring

### Features

- Smaller shell, suitable for relatively narrow installation space
- 6mm stainless steel probe
- IP65/NEMA4 protection
- 4-20mA, 0-10V, 0-5V, RS-485 output

### Technical Data

Model	KTH400
Power supply	16-30VDC ((2 wire 4-20mA)/16-30V AC or V DC ( 3 wire 0-5V/0-10V/4-20mA/RS 485 )
Output	4-20mA / 0-5V / 0-10V/ RS 485
Operating temperature	-35°C ... +70°C
Storage temperature	-40°C ... +60°C
Operating humidity	0 ... 100%RH
Max wind / flow speed	30m/s
Electromagnetic compatibility	EN61326-1 (Industrial Environment)
Housing material	PC+ABS ( UL-V0 approved )
Protection class	IP65/NEMA 4
Cable gland	M16*1.5
<b>Measurement performance-Temperature</b>	
Measurement range	-35 ... +80°C
Accuracy	±0.3°C(20-60°C)
Temperature dependence	±0.01°C/°C
<b>Measurement performance-Humidity</b>	
Measurement range	0 ... 100 %RH
Accuracy	±2%(0-90% @25°C)/±3%(90-100%@25°C)
Temperature dependence	±1%RH/ 年

### Dimensions (mm)

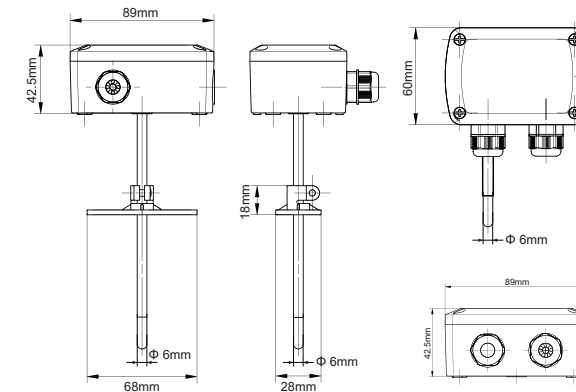

### Measurement Range Adjustment

ON	ON	ON	ON
1 2	1 2	1 2	1 2
-35 ... +75°C	-35 ... +35°C	0 ... +50°C	0 ... +80°C



Note: During the installation process of the device, the device cannot be powered on; you can set it by the DIP switch; after the device is assembled, it can be connected to the power supply.

### Ordering Guide

Model	Installation method	Filter	Output	Product number
KTH400-EWP	Wall	PTFE	4-20mA (2 wire)	03210460140100
KTH400-FWP	Duct		4-20mA (3 wire)	03210460140200
KTH400-GWP	Wall		0-10V	03210460140300
KTH400-HWP	Duct		RS485	03210460140400
KTH400-EDP	Wall		4-20mA (2 wire)	03210470140100
KTH400-FDP	Duct		4-20mA (3 wire)	03210470140200
KTH400-VDP	Wall		0-10V	03210470140300
KTH400-TDP	Duct		RS485	03210470140400

# KTH500 Temperature and Humidity Transmitter



**A: Duct-mounted**



**B: Wall-mounted**

## Features

- LCD display  
Large size backlight display
- Shell connected by hinge  
More convenient wiring and setting
- M16 M20 double cable gland  
Cable size 5...12mm
- Smooth and flat surface  
Prevent the pollution of the shell
- surface in harsh environment  
IP65/NEMA4

## Technical Data

Model	KTH500
Power supply	16-30V DC ( (2 wire 4-20mA)/16-30V AC or V DC ( 0-5V/0-10V/RS 485 )
Output	4-20mA / 0-5V / 0-10V/ RS 485
Operating temperature	-35°C ... +70°C
Storage temperature	-40°C ... +80°C
Operating humidity	0~100%RH
Temperature range	DIP
Display	Backlight LCD
Max wind / flow speed	30m/s
Electromagnetic compatibility	EN61326-1 (Industrial Environment)
Housing material	PC+ABS(UL-V0 approved )
Protection class	IP65/NEMA 4
Cable gland	M16*1.5/M20*1.5
<b>Measurement performance-Temperature</b>	
Measurement range	-35 ... +80°C
Accuracy	±0.3°C(20-60°C)
Temperature dependence	±0.01°C/°C
<b>Measurement performance-Humidity</b>	
Measurement range	0 ... 100%RH
Accuracy	±2%(0-90%@25°C)/±3%(90-100%@25°C)
Temperature dependence	±1%RH/year

## Description

KTH500 temperature and humidity transmitter can be used for measuring humidity and temperature in various HVAC applications, as well as monitoring building energy management systems; this series of products includes duct-mounted and IP65-rated wall-mounted; KTH500 series temperature and humidity transmitter is easy to install, has the characteristics of high precision, stable and reliable operation, and is an ideal choice for various harsh environments.

## Application

- HVAC system
- Greenhouse
- Food transportation
- Refrigeration
- Clean room environment monitoring

## Dimensions (mm)

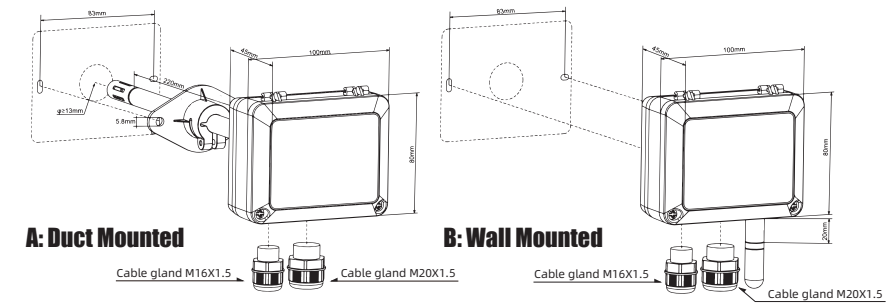

**A: Duct Mounted**

**B: Wall Mounted**

## Measurement Range Adjustment

ON	ON	ON	ON
1 2	1 2	1 2	1 2
-35 ... +75°C	-35 ... +35°C	0 ... +50°C	0 ... +80°C

**!** Note: During the installation process of the device, the device cannot be powered on; you can set it by the DIP switch; after the device is assembled, it can be connected to the power supply.

## Ordering Guide

Model	Installation method	Filter	Output	Product number
KTH500-EWP	Wall	PTFE	4-20mA (2 wire)	03190460140100
KTH500-FWP			4-20mA (3 wire)	03190460140200
KTH500-GWP			0-10V	03190460140300
KTH500-HWP			RS485	03190460140400
KTH500-EWS	Wall	Sintered stainless steel	4-20mA (2 wire)	03190460150100
KTH500-FWS			4-20mA (3 wire)	03190460150200
KTH500-GWS			0-10V	03190460150300
KTH500-HWS			RS485	03190460150400
KTH500-EDP	Duct	PTFE	4-20mA (2 wire)	03190470140100
KTH500-FDP			4-20mA (3 wire)	03190470140200
KTH500-GDP			0-10V (3 wire)	03190470140300
KTH500-HDP			RS485	03190470140400
KTH500-EDS	Duct	Sintered stainless steel	4-20mA (2 wire)	03190470150100
KTH500-FDS			4-20mA (3 wire)	03190470150200
KTH500-GDS			0-10V	03190470150300
KTH500-HDS			RS485	03190470150400

# KTH510 Temperature and Humidity Transmitter

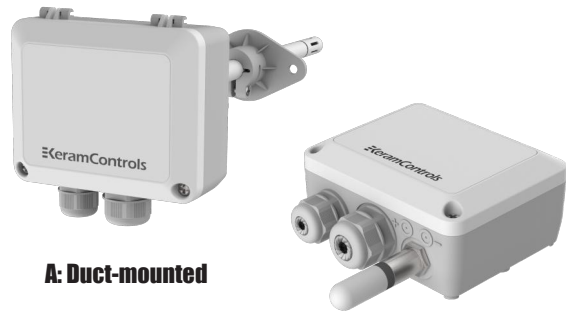

A: Duct-mounted

B: Wall-mounted

### Description

KTH510 temperature and humidity transmitter can be used for measuring humidity and temperature in various HVAC applications, as well as monitoring building energy management systems; this series of products includes duct-mounted and IP65-rated wall-mounted; KTH510 series temperature and humidity transmitter is easy to install, has the characteristics of high precision, stable and reliable operation, and is an ideal choice for various harsh environments.

### Application

- HVAC system
- Greenhouse
- Food transportation
- Refrigeration
- Clean room environment monitoring

### Features

- Shell connected by hinge  
More convenient wiring and setting
- M16 M20 double cable gland  
Cable size 5...12mm
- Smooth and at surface  
Prevent the pollution of the shell surface in harsh environment
- IP65/NEMA4

### Technical Data

Model	KTH510
Power supply	16-30V DC ((2 wire 4-20mA)/16-30V AC or V DC( 0-5V/0-10V/RS-485)
Output	4-20mA/0-5V/0-10V/RS-485
Operating temperature	-35°C ... +70°C
Storage temperature	-40°C ... +60°C
Operating humidity	0 ... 100%RH
Temperature range	DIP
Max wind / flow speed	30m/s
Electromagnetic compatibility	EN61326-1 (Industrial Environment)
Housing material	PC+ABS( UL-V0 approved )
Protection class	IP65/NEMA 4
Cable gland	M16*1.5/M20*1.5
<b>Measurement performance-Temperature</b>	
Measurement range	-35 ... +80 °C
Accuracy	±0.3°C (20-60°C)
Temperature dependence	±0.01 °C/°C
<b>Measurement performance-Humidity</b>	
Measurement range	0 ... 100%RH
Accuracy	±2%(0-90%@25°C)/±3%(90-100%@25°C)
Temperature dependence	±1%RH/year

### Dimensions (mm)

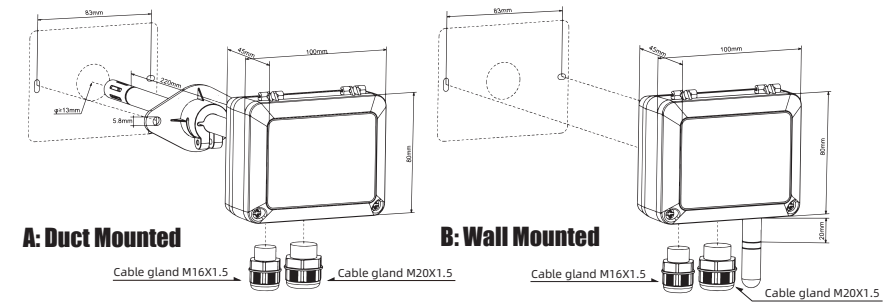

### Measurement Range Adjustment

ON	ON	ON	ON
1 2	1 2	1 2	1 2
-35 ... +75°C	-35 ... +35°C	0 ... +50°C	0 ... +80°C



Note: During the installation process of the device, the device cannot be powered on; you can set it by the DIP switch; after the device is assembled, it can be connected to the power supply.

### Ordering Guide

Model	Installation method	Filter	Output	Product number
KTH510-EWP	Wall	PTFE	4-20mA (2 wire)	03190460140100
KTH510-FWP			4-20mA (3 wire)	03190460140200
KTH510-GWP			0-10V	03190460140300
KTH510-HWP			RS485	03190460140400
KTH510-EWS	Wall	Sintered stainless steel	4-20mA (2 wire)	03190460150100
KTH510-FWS			4-20mA (3 wire)	03190460150200
KTH510-GWS			0-10V	03190460150300
KTH510-HWS			RS485	03190460150400
KTH510-EDP	Duct	PTFE	4-20mA (2 wire)	03190470140100
KTH510-FDP			4-20mA (3 wire)	03190470140200
KTH510-GDP			0-10V	03190470140300
KTH510-HDP			RS485	03190470140400
KTH510-EDS	Duct	Sintered stainless steel	4-20mA (2 wire)	03190470150100
KTH510-FDS			4-20mA (3 wire)	03190470150200
KTH510-GDS			0-10V	03190470150300
KTH510-HDS			RS485	03190470150400



### Features

- LCD display
  - Large size backlight display
- Shell connected by hinge
  - More convenient wiring and setting
- M16 M20 double cable gland
  - Cable size 5...12mm
- Smooth and at surface
  - Prevent the pollution of the
- shell surface in harsh environment
  - IP65/NEMA4

### Description

The KTH600 humidity and temperature transmitter can be used to measure relative humidity and temperature in various HVAC applications, as well as monitor building energy management systems. KTH600 adopts split remote probe, the probe removal and replacement can be done easily without adjusting the transmitter. KTH600 series temperature and humidity transmitter is easy to install, has high precision, stable and reliable operation, and is an ideal choice for various harsh environments.

### Application

- HVAC system
- Greenhouse
- Food transportation
- Refrigeration
- Clean room environment monitoring

### Technical Data

Model	KTH600
Power supply	16-30V DC ( 2 wire 4-20mA)/16-30V AC or V DC ( 0-5V/0-10V/RS-485 )
Output	4-20mA / 0-5V / 0-10V/ RS-485
Operating temperature	-35 ... +70
Storage temperature	-40 ... +60
Operating humidity	0~100 %RH
Temperature range	DIP
Display	Backlight LCD
Max wind / flow speed	30 m/s
Electromagnetic compatibility	EN61326-1 ( Industrial Environment )
Housing material	PC+ABS ( UL-V0 approved )
Protection class	IP65 / NEMA 4
Cable gland	M16*1.5/M20*1.5
Cable length	PVC 1.5/3m
<b>Measurement performance-Temperature</b>	
Measurement range	-35 ... +80 °C
Accuracy	±0.3°C (20-60°C)
Temperature dependence	±0.01 °C/°C
<b>Measurement performance-Humidity</b>	
Measurement range	0 ... 100 %RH
Accuracy	±2% (0-90% @25°C) / ±3% (90-100% @25°C)
Temperature dependence	±1 %RH/year

### Dimensions (mm)

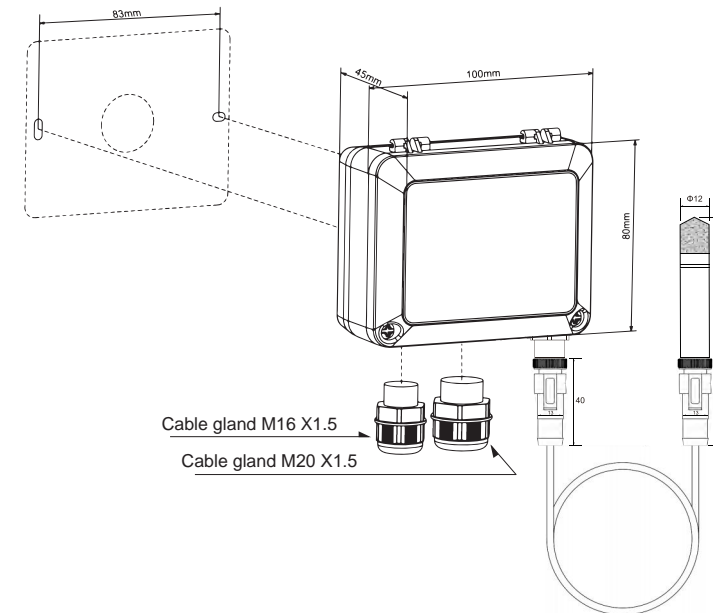

### Measurement Range Adjustment

ON	ON	ON	ON
1 2	1 2	1 2	1 2
-35 ... +75°C	-35 ... +35°C	0 ... +50°C	0 ... +80°C



Note: During the installation process of the device, the device cannot be powered on; you can set it by the DIP switch; after the device is assembled, it can be connected to the power supply.

# KTH600 Temperature and Humidity Transmitter

# KTH610 Temperature and Humidity Transmitter

## Ordering Guide

● Backlight LCD ■ No Backlight LCD × No display

Model	Filter	Output	Display	Cable length	Product number	
KTH600-EDS3M	Sintered stainless steel	4-20mA (2 wire)	■	3m	03200480140104	
KTH600-EDS5M				5m	03200480140105	
KTH600-EDS10M				10m	03200480140106	
KTH600-FDS3M		4-20mA (3 wire)		●	3m	03200480140204
KTH600-FDS5M					5m	03200480140205
KTH600-FDS10M					10m	03200480140206
KTH600-GDS3M		0-10V	●		3m	03200480140304
KTH600-GDS5M					5m	03200480140305
KTH600-GDS10M					10m	03200480140306
KTH600-HDS3M		RS485		■	3m	03200480140404
KTH600-HDS5M					5m	03200480140405
KTH600-HDS10M					10m	03200480140406
KTH600-EDP3M	PTFE	4-20mA (2 wire)	■		3m	03200480150104
KTH600-EDP5M					5m	03200480150105
KTH600-EDP10M					10m	03200480150106
KTH600-FDP3M		4-20mA (3 wire)		●	3m	03200480150204
KTH600-FDP5M					5m	03200480150205
KTH600-FDP10M					10m	03200480150206
KTH600-GDP3M		0-10V	●		3m	03200480150304
KTH600-GDP5M					5m	03200480150305
KTH600-GDP10M					10m	03200480150306
KTH600-HDP3M		RS485		■	3m	03200480150404
KTH600-HDP5M					5m	03200480150405
KTH600-HDP10M					10m	03200480150406
KTH600-E-P3M	Sintered stainless steel	4-20mA (2 wire)	■		3m	03200490140104
KTH600-E-P5M					5m	03200490140105
KTH600-E-P10M					10m	03200490140106
KTH600-F-P3M		4-20mA (3 wire)		●	3m	03200490140204
KTH600-F-P5M					5m	03200490140205
KTH600-F-P10M					10m	03200490140206
KTH600-G-P3M		0-10V	●		3m	03200490140304
KTH600-G-P5M					5m	03200490140305
KTH600-G-P10M					10m	03200490140306
KTH600-H-P3M		RS485		■	3m	03200490140404
KTH600-H-P5M					5m	03200490140405
KTH600-H-P10M					10m	03200490140406
KTH600-E-S3M	Sintered stainless steel	4-20mA (2 wire)	■		3m	03200490150104
KTH600-E-S5M					5m	03200490150105
KTH600-E-S10M					10m	03200490150106
KTH600-F-S3M		4-20mA (3 wire)		●	3m	03200490150204
KTH600-F-S5M					5m	03200490150205
KTH600-F-S10M					10m	03200490150206
KTH600-G-S3M		0-10V	●		3m	03200490150304
KTH600-G-S5M					5m	03200490150305
KTH600-G-S10M					10m	03200490150306
KTH600-H-S3M		RS485		■	3m	03200490150404
KTH600-H-S5M					5m	03200490150405
KTH600-H-S10M					10m	03200490150406



## Description

The KTH600 humidity and temperature transmitter can be used to measure relative humidity and temperature in various HVAC applications, as well as monitor building energy management systems. KTH600 adopts split remote probe, the probe removal and replacement can be done easily without adjusting the transmitter. KTH600 series temperature and humidity transmitter is easy to install, has high precision, stable and reliable operation, and is an ideal choice for various harsh environments.

## Features

- Shell connected by hinge  
More convenient wiring and setting
- M16 M20 double cable gland  
Cable size 5...12mm
- Smooth and at surface  
Prevent the pollution of the shell surface in harsh environment
- IP65/NEMA4

## Application

- HVAC system
- Greenhouse
- Food transportation
- Refrigeration
- Clean room environment monitoring

## Technical Data

Model	KTH610
Power supply	16-30V DC ( 2wire 4-20mA)/16-30V AC 或者 V DC ( 0-5V/0-10V/RS-485 )
Output	4-20mA / 0-5V / 0-10V/ RS-485
Operating temperature	-35 ... +70
Storage temperature	-40 ... +60
Operating humidity	0~100 %RH
Temperature range	DIP
Max wind / flow speed	30 m/s
Electromagnetic compatibility	EN61326-1 ( Industrial Environment )
Housing material	PC+ABS ( UL-V0 approved )
Protection class	IP65 / NEMA 4
Cable gland	M16*1.5/M20*1.5
Cable length	PVC 1.5/3m
<b>Measurement performance-Temperature</b>	
Measurement range	-35 ... +80 °C
Accuracy	±0.3°C (20-60°C)
Temperature dependence	±0.01 °C/°C
<b>Measurement performance-Humidity</b>	
Measurement range	0 ... 100 %RH
Accuracy	±2% (0-90% @25°C) / ±3% (90-100% @25°C)
Temperature dependence	±1 %RH/year

## Dimensions (mm)

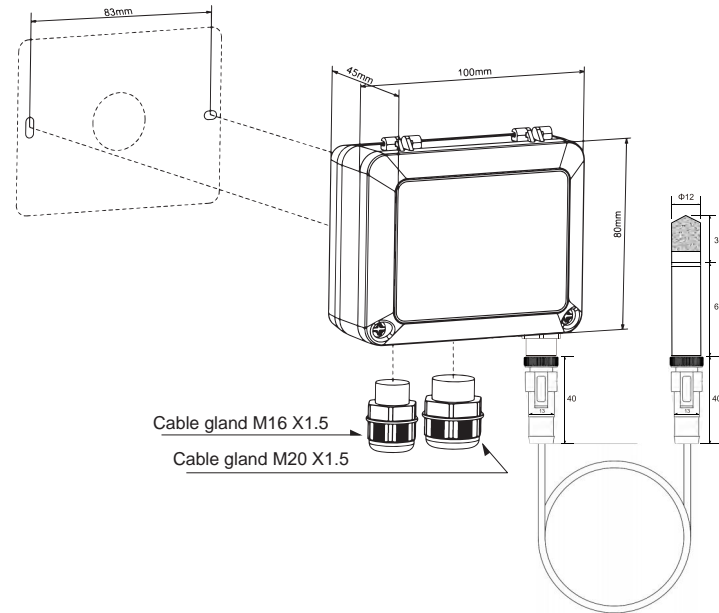

## Measurement Range Adjustment

ON 1 2	ON 1 2	ON 1 2	ON 1 2
-35 ... +75°C	-35 ... +35°C	0 ... +50°C	0 ... +80°C

**!** Note: During the installation process of the device, the device cannot be powered on; you can set it by the DIP switch; after the device is assembled, it can be connected to the power supply.

## Ordering Guide

Model	Filter	Output	Cable length	Product number
KTH610-EDS3M	Sintered stainless steel	4-20mA (2 wire)	3m	03430480140104
KTH610-EDS5M	Sintered stainless steel	4-20mA (2 wire)	5m	03430480140105
KTH610-EDS10M	Sintered stainless steel	4-20mA (2 wire)	10m	03430480140106
KTH610-FDS3M	Sintered stainless steel	4-20mA (3 wire)	3m	03430480140204
KTH610-FDS5M	Sintered stainless steel	4-20mA (3 wire)	5m	03430480140205
KTH610-FDS10M	Sintered stainless steel	4-20mA (3 wire)	10m	03430480140206
KTH610-GDS3M	Sintered stainless steel	0-10V (3 wire)	3m	03430480140304
KTH610-GDS5M	Sintered stainless steel	0-10V (3 wire)	5m	03430480140305
KTH610-GDS10M	Sintered stainless steel	0-10V (3 wire)	10m	03430480140306
KTH610-HDS3M	Sintered stainless steel	RS485	3m	03430480140404
KTH610-HDS5M	Sintered stainless steel	RS485	5m	03430480140405
KTH610-HDS10M	Sintered stainless steel	RS485	10m	03430480140406
KTH610-EDP3M	PTFE	4-20mA (2 wire)	3m	03430480150104
KTH610-EDP5M	PTFE	4-20mA (2 wire)	5m	03430480150105
KTH610-EDP10M	PTFE	4-20mA (2 wire)	10m	03430480150106
KTH610-FDP3M	PTFE	4-20mA (3 wire)	3m	03430480150204
KTH610-FDP5M	PTFE	4-20mA (3 wire)	5m	03430480150205
KTH610-FDP10M	PTFE	4-20mA (3 wire)	10m	03430480150206
KTH610-GDP3M	PTFE	0-10V (3 wire)	3m	03430480150304
KTH610-GDP5M	PTFE	0-10V (3 wire)	5m	03430480150305
KTH610-GDP10M	PTFE	0-10V (3 wire)	10m	03430480150306
KTH610-HDP3M	PTFE	RS485	3m	03430480150404
KTH610-HDP5M	PTFE	RS485	5m	03430480150405
KTH610-HDP10M	PTFE	RS485	10m	03430480150406
KTH610-E-P3M	PTFE	4-20mA (2 wire)	3m	03430490140104
KTH610-E-P5M	PTFE	4-20mA (2 wire)	5m	03430490140105
KTH610-E-P10M	PTFE	4-20mA (2 wire)	10m	03430490140106
KTH610-F-P3M	PTFE	4-20mA (3 wire)	3m	03430490140204
KTH610-F-P5M	PTFE	4-20mA (3 wire)	5m	03430490140205
KTH610-F-P10M	PTFE	4-20mA (3 wire)	10m	03430490140206
KTH610-G-P3M	PTFE	0-10V (3 wire)	3m	03430490140304
KTH610-G-P5M	PTFE	0-10V (3 wire)	5m	03430490140305
KTH610-G-P10M	PTFE	0-10V (3 wire)	10m	03430490140306
KTH610-H-P3M	PTFE	RS485	3m	03430490140404
KTH610-H-P5M	PTFE	RS485	5m	03430490140405
KTH610-H-P10M	PTFE	RS485	10m	03430490140406
KTH610-E-S3M	Sintered stainless steel	4-20mA (2 wire)	3m	03430490150104
KTH610-E-S5M	Sintered stainless steel	4-20mA (2 wire)	5m	03430490150105
KTH610-E-S10M	Sintered stainless steel	4-20mA (2 wire)	10m	03430490150106
KTH610-F-S3M	Sintered stainless steel	4-20mA (3 wire)	3m	03430490150204
KTH610-F-S5M	Sintered stainless steel	4-20mA (3 wire)	5m	03430490150205
KTH610-F-S10M	Sintered stainless steel	4-20mA (3 wire)	10m	03430490150206
KTH610-G-S3M	Sintered stainless steel	0-10V (3 wire)	3m	03430490150304
KTH610-G-S5M	Sintered stainless steel	0-10V (3 wire)	5m	03430490150305
KTH610-G-S10M	Sintered stainless steel	0-10V (3 wire)	10m	03430490150306
KTH610-H-S3M	Sintered stainless steel	RS485	3m	03430490150404
KTH610-H-S5M	Sintered stainless steel	RS485	5m	03430490150405
KTH610-H-S10M	Sintered stainless steel	RS485	10m	03430490150406



### Description

HTP110 is a digital output temperature and humidity probe, which is stable and durable, and can be easily installed and removed. HTP110 probe can be easily and quickly connected to the cable through the M12 interface, or other M12 interface compatible cables can be used according to the installation requirements.

HTP110 uses a plastic casing with a protection level of IP65, which can meet the working environment under various extreme conditions.

### Dimensions ( mm )

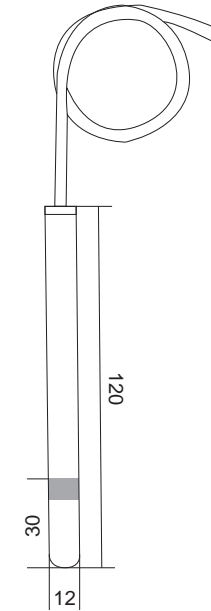

### Application

- Agriculture
- HVAC system
- Cleanroom
- Refrigeration system measurement
- Commercial building automation system
- Transportation hub

### Features

- Low power consumption
- Easy disassembly
- Pluggable cable with standard M12 connector
- IP65 degree of protection

### Technical Data

	Model	HTP110
	Power Supply	3.8V-5V
	Operating temperature	-40 ... 80
	Storage temperature	-40 ... 60
Temperature	Accuracy	± 0.2 at +5 ~+60
	Range	0~100 % RH
Humidity	Accuracy	2% at 25 & 20~80%RH
	Repeat stability	< ± 0.5% RH / year
	Sensitive component protection	Coating process
	Housing material	316 Stainless steel
	Protection class	IP65 / NEMA 4
	Cable gland	M12*1

### Ordering Guide

Model	Output	Cable length	Product number
HTP110-E-1M	4-20mA	1m	03430140260100
HTP110-G-1M	0-10V	3m	03430140260300
HTP110-H-1M	RS485	5m	03430140260400
HTP110-E-3M	4-20mA	1m	03430140160100
HTP110-G-3M	0-10V	3m	03430140160300
HTP110-H-3M	RS485	5m	03430140160400
HTP110-E-5M	4-20mA	1m	03430140170100
HTP110-G-5M	0-10V	3m	03430140170300
HTP110-H-5M	RS485	5m	03430140170400



### Description

HTP120 is a digital output temperature and humidity probe, which is stable and durable, and can be easily installed and removed. The HTP120 probe can be easily and quickly connected to the cable through the M12 interface, or other M12 interface compatible cables can be used according to the installation requirements.

HTP120 uses a stainless steel casing with a protection level of IP65, which can meet the working environment under various extreme conditions.

### Dimensions (mm)

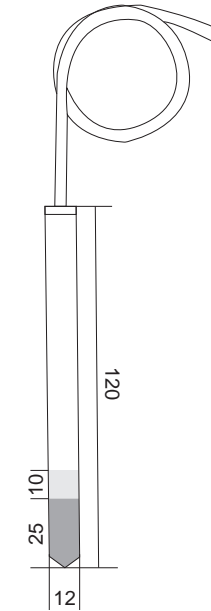

### Application

- Agriculture
- HVAC system
- Cleanroom
- Refrigeration system measurement
- Commercial building automation system
- Transportation hub

### Features

- Low power consumption
- Easy disassembly
- Pluggable cable with standard M12
- connector IP65 degree of protection

### Technical Data

Model		HTP120
Power Supply		3.8V -5V
Operating temperature		-40 ... 80
Storage temperature		-40 ... 60
Temperature	Accuracy	± 0.2 at +5 ~+60
	Range	0~100 % RH
Humidity	Accuracy	2% at 25 & 20~80%RH
	Repeat stability	< ± 0.5% RH / year
	Sensitive component protection	Coating process
Housing material		316Stainless steel
Protection class		IP65 / NEMA 4
Cable gland		M12*1

### Ordering Guide

Model	Output	Cable length	Product number
HTP120-E-1M	4-20mA	1m	03440140260100
HTP120-G-1M	0-10V	3m	03440140260300
HTP120-H-1M	RS485	5m	03440140260400
HTP120-E-3M	4-20mA	1m	03440140160100
HTP120-G-3M	0-10V	3m	03440140160300
HTP120-H-3M	RS485	5m	03440140160400
HTP120-E-5M	4-20mA	1m	03440140170100
HTP120-G-5M	0-10V	3m	03440140170300
HTP120-H-5M	RS485	5m	03440140170400





# KTC110 Temperature Sensor



## Description

KTC110 series sensors are low-cost temperature sensors specially designed for temperature measurement in the field of HVAC, and are suitable for process control of commercial building automation systems.

KTC110 series adopts passive resistance signal output, and is used for passive temperature output with NTC10K, Pt100, Pt1000 and other temperature sensitive components. The IP65 cable interface can effectively ensure the waterproof performance of the sensor.

## Application

- Building automation
- HVAC Environmental control

## Features

- High protection level
- A variety of temperature sensitive elements and cable
- Lengths are available A variety of accessories are available

## Technical Data

Model	KTC110	
Temperature sensor	Sensitive components	Standard resistance
	NTC10K B3435	$R_{25}: 10K\Omega \pm 1\%$
	Pt100	$R_0: 100\Omega$
	Pt1000	$R_0: 1000\Omega$
Component connection	2 wire or 3 wire	
Cable material	PVC	
Sensor probe material	316 Stainless steel	
Protection class	IP65/NEMA4	
Operating temperature	-30 ... +100°C	
Storage temperature	-30 ... +70°C	

## Dimensions ( mm )

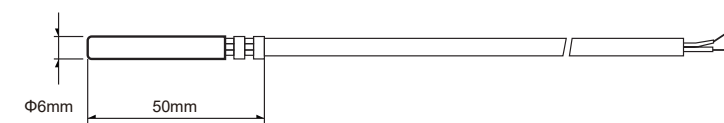

## Flexible and reliable temperature measurement device

Keram Controls temperature sensors cover active and passive series, and the active series provide range setting and switching to meet various measurement needs.

A variety of installation types, novel and convenient installation methods to meet all typical applications.



# KTC110 Temperature Sensor

# KTC111 Temperature Sensor

## Ordering Guide

Model	Sensitive components	Cable length	Wiring	Product number
KTC110-2EJ	NTC 10K	1m	2 line	04260520261300
KTC110-3EJ			3 line	04260520261400
KTC110-2EK		2m	2 line	04260520271300
KTC110-3EK			3 line	04260520271400
KTC110-2EL		3m	2 line	04260520161300
KTC110-3EL			3 line	04260520161400
KTC110-2EM		4m	2 line	04260520291300
KTC110-3EM			3 line	04260520291400
KTC110-2EN		5m	2 line	04260520171300
KTC110-3EN			3 line	04260520171400
KTC110-2EO	10m	2 line	04260520181300	
KTC110-3EO		3 line	04260520181400	
KTC110-2FJ	PT100	1m	2 line	04260530261300
KTC110-3FJ			3 line	04260530261400
KTC110-2FK		2m	2 line	04260530271300
KTC110-3FK			3 line	04260530271400
KTC110-2FL		3m	2 line	04260530161300
KTC110-3FL			3 line	04260530161400
KTC110-2FM		4m	2 line	04260530291300
KTC110-3FM			3 line	04260530291400
KTC110-2FN		5m	2 line	04260530171300
KTC110-3FN			3 line	04260530171400
KTC110-2FO	10m	2 line	04260530181300	
KTC110-3FO		3 line	04260530181400	
KTC110-2GJ	PT1000	1m	2 line	04260540261300
KTC110-3GJ			3 line	04260540261400
KTC110-2GK		2m	2 line	04260540271300
KTC110-3GK			3 line	04260540271400
KTC110-2GL		3m	2 line	04260540161300
KTC110-3GL			3 line	04260540161400
KTC110-2GM		4m	2 line	04260540291300
KTC110-3GM			3 line	04260540291400
KTC110-2GN		5m	2 line	04260540171300
KTC110-3GN			3 line	04260540171400
KTC110-2GO	10m	2 line	04260540181300	
KTC110-3GO		3 line	04260540181400	



## Application

- Building automation
- HVAC Environmental control

## Technical Data

Model	KTC111	
Temperature sensor	Sensitive components	Standard resistance
	NTC10K B3435	$R_{25}:10K\Omega\pm 1\%$
	Pt100	$R_0: 100\Omega$
	Pt1000	$R_0:1000\Omega$
Component connection	2 wire or 3 wire	
Cable material	Glass fiber, Silicone, PTFE	
Sensor probe material	316 Stainless steel	
Protection class	IP65/NEMA4	
Operating temperature	Glass fiber	0 ... 350°C
	Silicone	-60 ... 180°C
	PTFE	-20 ... 250°C
Storage temperature	-30 ... +70°C	

## Dimensions ( mm )

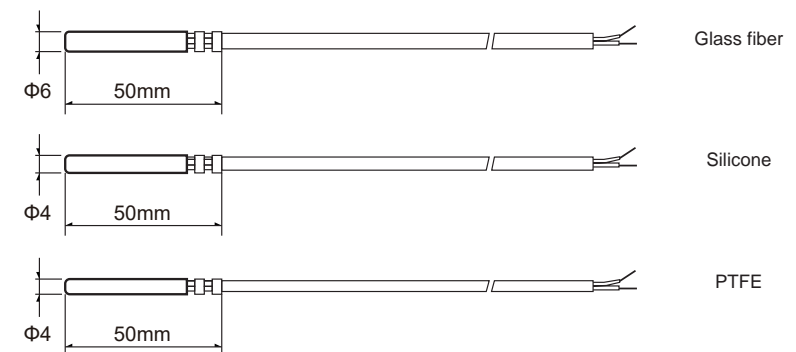

# KTC111 Temperature Sensor

# KTC111 Temperature Sensor

## Ordering Guide

Model	Sensitive components	Cable length	Wiring	Cable material	Product number	
KTC111-2EJA	NTC 10K	1m	2 wire	Glass fiber	04270520261307	
KTC111-2EJB				Silicone	04270520261308	
KTC111-2EJC				PTFE	04270520261309	
KTC111-3EJA			3 wire	Glass fiber	04270520261407	
KTC111-3EJB				Silicone	04270520261408	
KTC111-3EJC				PTFE	04270520261409	
KTC111-2EKA		2m	2 wire	Glass fiber	04270520271307	
KTC111-2EKB				Silicone	04270520271308	
KTC111-2EKC				PTFE	04270520271309	
KTC111-3EKA			3 wire	Glass fiber	04270520271407	
KTC111-3EKB				Silicone	04270520271408	
KTC111-3EKC				PTFE	04270520271409	
KTC111-2ELA		3m	2 wire	Glass fiber	04270520161307	
KTC111-2ELB				Silicone	04270520161308	
KTC111-2ELC				PTFE	04270520161309	
KTC111-3ELA			3 wire	Glass fiber	04270520161407	
KTC111-3ELB				Silicone	04270520161408	
KTC111-3ELC				PTFE	04270520161409	
KTC111-2EMA			4m	2 wire	Glass fiber	04270520291307
KTC111-2EMB					Silicone	04270520291308
KTC111-2EMC					PTFE	04270520291309
KTC111-3EMA		3 wire		Glass fiber	04270520291407	
KTC111-3EMB				Silicone	04270520291408	
KTC111-3EMC				PTFE	04270520291409	
KTC111-2ENA		5m	2 wire	Glass fiber	04270520171307	
KTC111-2ENB				Silicone	04270520171308	
KTC111-2ENC				PTFE	04270520171309	
KTC111-3ENA			3 wire	Glass fiber	04270520171407	
KTC111-3ENB				Silicone	04270520171408	
KTC111-3ENC				PTFE	04270520171409	
KTC111-2EOA			10m	2 wire	Glass fiber	04270520181307
KTC111-2EOB					Silicone	04270520181308
KTC111-2EOC					PTFE	04270520181309
KTC111-3EOA		3 wire		Glass fiber	04270520181407	
KTC111-3EOB				Silicone	04270520181408	
KTC111-3EOC				PTFE	04270520181409	
KTC111-2FJA	PT100	1m	2 wire	Glass fiber	04270530261307	
KTC111-2FJB				Silicone	04270530261308	
KTC111-2FJC				PTFE	04270530261309	
KTC111-3FJA			3 wire	Glass fiber	04270530261407	
KTC111-3FJB				Silicone	04270530261408	
KTC111-3FJC				PTFE	04270530261409	
KTC111-2FKA		2m	2 wire	Glass fiber	04270530271307	
KTC111-2FKB				Silicone	04270530271308	
KTC111-2FKC				PTFE	04270530271309	
KTC111-3FKA			3 wire	Glass fiber	04270530271407	
KTC111-3FKB				Silicone	04270530271408	
KTC111-3FKC				PTFE	04270530271409	
KTC111-2FLA		3m	2 wire	Glass fiber	04270530161307	
KTC111-2FLB				Silicone	04270530161308	
KTC111-2FLC				PTFE	04270530161309	
KTC111-3FLA			3 wire	Glass fiber	04270530161407	
KTC111-3FLB				Silicone	04270530161408	
KTC111-3FLC				PTFE	04270530161409	

## Ordering Guide

Model	Sensitive components	Cable length	Wiring	Cable material	Product number	
KTC111-2FMA	PT100	3m	2 wire	Glass fiber	04270530171307	
KTC111-2FMB				Silicone	04270530171308	
KTC111-2FMC				PTFE	04270530171309	
KTC111-3FMA			3 wire	Glass fiber	04270530171407	
KTC111-3FMB				Silicone	04270530171408	
KTC111-3FMC				PTFE	04270530171409	
KTC111-2FNA		4m	2 wire	Glass fiber	04270530181307	
KTC111-2FNB				Silicone	04270530181308	
KTC111-2FNC				PTFE	04270530181309	
KTC111-3FNA			3 wire	Glass fiber	04270530181407	
KTC111-3FNB				Silicone	04270530181408	
KTC111-3FNC				PTFE	04270530181409	
KTC111-2FOA		10m	2 wire	Glass fiber	04270530181307	
KTC111-2FOB				Silicone	04270530181308	
KTC111-2FOC				PTFE	04270530181309	
KTC111-3FOA			3 wire	Glass fiber	04270530181407	
KTC111-3FOB				Silicone	04270530181408	
KTC111-3FOC				PTFE	04270530181409	
KTC111-2GJA			1m	2 wire	Glass fiber	04270540261307
KTC111-2GJB					Silicone	04270540261308
KTC111-2GJC					PTFE	04270540261309
KTC111-3GJA		3 wire		Glass fiber	04270540261407	
KTC111-3GJB				Silicone	04270540261408	
KTC111-3GJC				PTFE	04270540261409	
KTC111-2GKA		2m	2 wire	Glass fiber	04270540271307	
KTC111-2GKB				Silicone	04270540271308	
KTC111-2GKC				PTFE	04270540271309	
KTC111-3GKA			3 wire	Glass fiber	04270540271407	
KTC111-3GKB				Silicone	04270540271408	
KTC111-3GKC				PTFE	04270540271409	
KTC111-2GLA			3m	2 wire	Glass fiber	04270540161307
KTC111-2GLB					Silicone	04270540161308
KTC111-2GLC					PTFE	04270540161309
KTC111-3GLA		3 wire		Glass fiber	04270540161407	
KTC111-3GLB				Silicone	04270540161408	
KTC111-3GLC				PTFE	04270540161409	
KTC111-2GMA	PT1000	4m	2 wire	Glass fiber	04270540171307	
KTC111-2GMB				Silicone	04270540171308	
KTC111-2GMC				PTFE	04270540171309	
KTC111-3GMA			3 wire	Glass fiber	04270540171407	
KTC111-3GMB				Silicone	04270540171408	
KTC111-3GMC				PTFE	04270540171409	
KTC111-2GNA		5m	2 wire	Glass fiber	04270540181307	
KTC111-2GNB				Silicone	04270540181308	
KTC111-2GNC				PTFE	04270540181309	
KTC111-3GNA			3 wire	Glass fiber	04270540181407	
KTC111-3GNB				Silicone	04270540181408	
KTC111-3GNC				PTFE	04270540181409	
KTC111-2GOA			10m	2 wire	Glass fiber	04270540181307
KTC111-2GOB					Silicone	04270540181308
KTC111-2GOC					PTFE	04270540181309
KTC111-3GOA		3 wire		Glass fiber	04270540181407	
KTC111-3GOB				Silicone	04270540181408	
KTC111-3GOC				PTFE	04270540181409	



### Description

KTS100 series wall-mounted sensor is a low-cost temperature sensor specially designed for temperature measurement in the field of HVAC; it is suitable for building automation control systems (BA systems) in commercial buildings and other conventional buildings.

The IP65 protection level is also convenient for outdoor measurement.

### Features

- Temperature range from -40 to +200
- Resistance output
- Standard precision, visible attribute parameter table
- Protection level: IP65/NEMA4

### Application

KTS100 temperature sensor for temperature measurement in heating, ventilation and air conditioning systems.

### Technical Data

Model	KTS100
Temperature sensitive element	PT100 Class A sensitivity $\pm (0.15+0.002t)$
	PT 1000 Class A sensitivity $\pm (0.15+0.002t)$
	NTC 10k B3950 sensitivity B:3989K $\pm$ 1%
	NTC 10k B3435 sensitivity B:3435K $\pm$ 1%
	NTC 1k sensitivity B:3500K $\pm$ 1%
	NTC 2k sensitivity B:3977K $\pm$ 0.3%
Response time	<1min
Component connection	2 wire
Media	Air or liquid
Operating temperature	-40 ... +70°C
Storage temperature	-30 ... +70°C
Measurement range	-40 ... +200°C
Housing material	PC&ABS,UL94-V0
Protection class	IP65/NEMA 4
Cable gland	M16*1.5

### Dimensions ( mm )

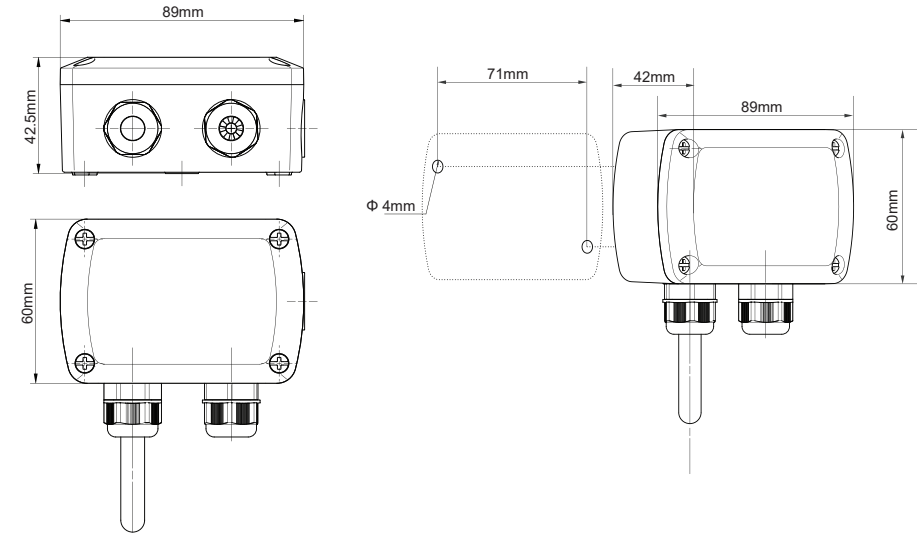

### Note On Disposal



Most Keram Controls products may contain valuable materials that should be recycled rather than treated as domestic waste. Please pay attention to the relevant regulations of local disposal.

### Product Certification



CE  
The certification of the products can be found on our website [https:// www.keramcontrols.com](https://www.keramcontrols.com).

### Ordering Guide

Model	Sensitive components	Product number
KTS100-1	PT100	04290530000000
KTS100-2	PT1000	04290540000000
KTS100-3	NTC 10K 3950	04290550000000
KTS100-4	NTC 10K 3435	04290520000000
KTS100-5	NTC 1K	04290560000000
KTS100-6	NTC 2K	04290570000000



## Description

KTS110 series pipe installation sensor is a low-cost temperature sensor specially designed for temperature measurement in the field of HVAC. It is suitable for building automatic control system (BA system) of commercial buildings and other conventional buildings. IP65 protection level is also convenient for outdoor measurement.

## Features

- Temperature range from -40 to +200
- Resistance output
- Standard precision, see attribute parameter table
- Protection class: IP65/NEMA4

## Application

KTS110 temperature sensor for temperature measurement in heating, ventilation and air conditioning systems.

## Technical Data

Model	KTS110
Temperature sensitive element	PT100 Class A sensitivity $\pm (0.15+0.002t)$
	PT 1000 Class A sensitivity $\pm (0.15+0.002t)$
	NTC 10k B3950 sensitivity B:3989K $\pm 1\%$
	NTC 10k B3435 sensitivity B:3435K $\pm 1\%$
	NTC 1k sensitivity B:3500K $\pm 1\%$
	NTC 2k sensitivity B:3977K $\pm 0.3\%$
Response time	<1min, 3m/s (590ft/min)/< 30s in the air pipeline, measuring the liquid in the pipeline
Component connection	2 wire
Media	Air or liquid
Operating temperature	-40 ... +110°C(Air duct )/-40 ... +200°C(liquid duct)
Storage temperature	-30 ... +70°C
Measurement range	-40 ... +200°C
Housing material	PC&ABS,UL94-V0
Protection class	IP65/NEMA 4
Cable gland	M16*1.5

## Dimensions (mm)

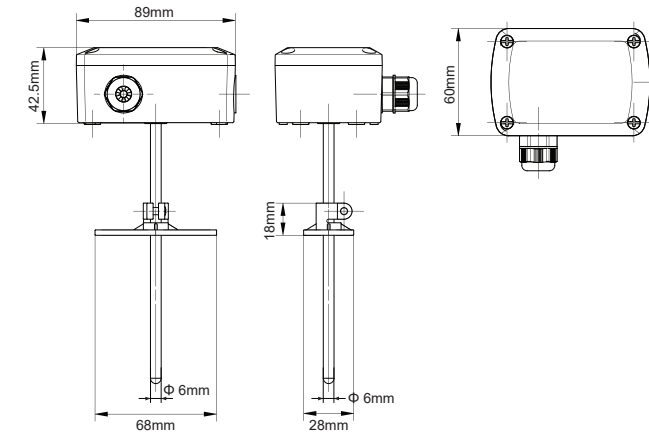

## Note On Disposal



Most Keram Controls products may contain valuable materials that should be recycled rather than treated as domestic waste. Please pay attention to the relevant regulations of local disposal.

## Product Certification



CE

The certification of the products can be found on our website [https:// www.keramcontrols.com](https://www.keramcontrols.com).

## Accessory Dimension drawing

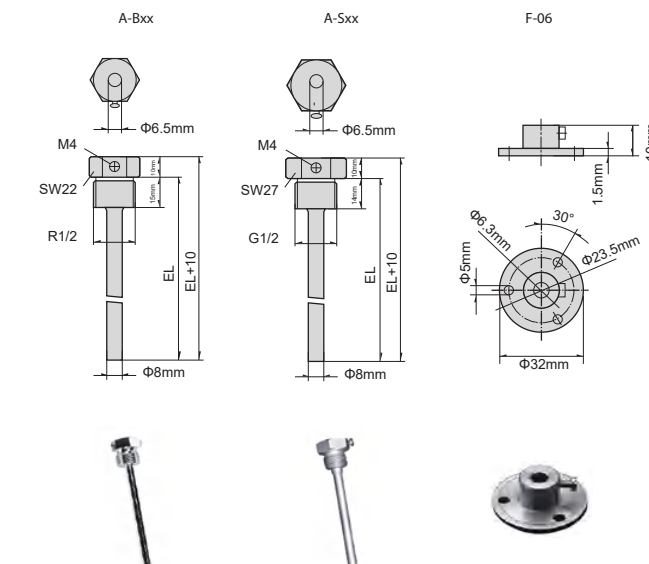

## Accessory

Model	Immersion casing diameter	Media	Maximum pressure	Max working temperature	Insertion length (EL)
A-B 50MM	8mm	Nickel-plated brass	10bar	150°C	50mm
A-B 100MM					100mm
A-B 150MM					150mm
A-B 200MM					200mm
A-B 250MM					250mm
A-B 300MM					300mm
A-B 350MM					350mm
A-B 400MM					400mm

Note: with neck tube(90mm)

Model	Immersion casing diameter	Media	Maximum pressure	Max working temperature	Insertion length (EL)
A-S 50MM	8mm	Nickel-plated brass	40bar	600°C	50mm
A-S 100MM					100mm
A-S 150MM					150mm
A-S 200MM					200mm
A-S 250MM					250mm
A-S 300MM					300mm
A-S 350MM					350mm
A-S 400MM					400mm

Note: with neck tube(90mm)

Model	Diameter	Maximum allowable diameter of metal pipe	Max working temperature	Material
F-06	32mm	6.3mm	700°C	Galvanized steel

Note: with neck tube(90mm)

## Ordering Guide

Model	Sensitive components	Probe length	Product number
KTS110-4A	NTC 10K 3435	65mm	04280520300000
KTS110-4B		120mm	04280520310000
KTS110-4C		150mm	04280520210000
KTS110-4D		300mm	04280520240000
KTS110-1A	PT100	65mm	04280530300000
KTS110-1B		120mm	04280530310000
KTS110-1C		150mm	04280530210000
KTS110-1D		300mm	04280530240000
KTS110-2A	PT1000	65mm	04280540300000
KTS110-2B		120mm	04280540310000
KTS110-2C		150mm	04280540210000
KTS110-2D		300mm	04280540240000
KTS110-3A	NTC 10K 3950	65mm	04280550300000
KTS110-3B		120mm	04280550310000
KTS110-3C		150mm	04280550210000
KTS110-3D		300mm	04280550240000
KTS110-5A	NTC 1K	65mm	04280560300000
KTS110-5B		120mm	04280560310000
KTS110-5C		150mm	04280560210000
KTS110-5D		300mm	04280560240000
KTS110-6A	NTC 2K	65mm	04280570300000
KTS110-6B		120mm	04280570310000
KTS110-6C		150mm	04280570210000
KTS110-6D		300mm	04280570240000



## Description

KTS120 series cable sensor is a low-cost temperature sensor specially designed for temperature measurement in various working environments. It can measure the temperature in air ducts and liquid pipes through different installation and fixing accessories.

## Features

- Temperature range from -40 to +200
- Resistance output
- Standard precision, see attribute parameter table
- Protection class: IP65/NEMA4

## Application

KTS110 temperature sensor for temperature measurement in heating, ventilation and air conditioning systems.

## Technical Data

Model	KTS120
Temperature sensitive element	PT100 Class A sensitivity $\pm (0.15+0.002t)$
	PT 1000 Class A sensitivity $\pm (0.15+0.002t)$
	NTC 10k B3950 sensitivity B:3989K $\pm$ 1%
	NTC 10k B3435 sensitivity B:3435K $\pm$ 1%
	NTC 1k sensitivity B:3500K $\pm$ 1%
Response time	NTC 2k sensitivity B:3977K $\pm$ 0.3%
	<1min/<30s, measure liquids in pipes
Component connection	2 wire
Media	Air or liquid
Operating temperature	-30 ... +70°C (Cable) / -30 ... +200°C (Probe)
Storage temperature	-30 ... +70°C
Measurement range	-40 ... +200°C
Housing material	PC&ABS, UL94-V0
Protection class	IP65/NEMA 4
Cable gland	M16*1.5

## Dimension ( mm )

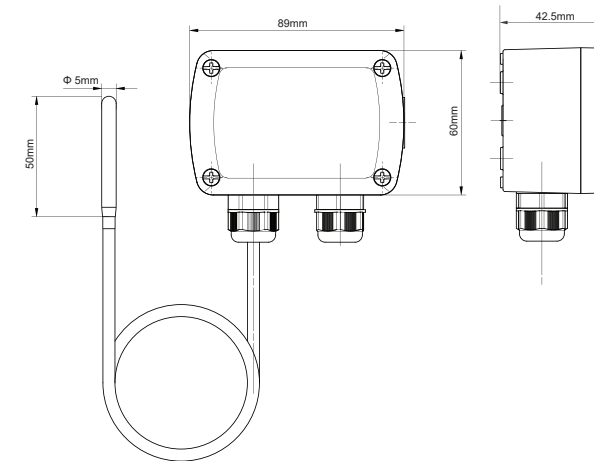

## Accessory

### Temperature compensation

Cable length	Cable resistance	Temperature compensation
0.5m	0.086 $\Omega$	0.22°C
2m	0.344 $\Omega$	0.88°C
3m	0.516 $\Omega$	1.32°C

\* When the temperature resistance of high resistance value ( $R > 1000$ ), the temperature compensation is negligible.

## Ordering Guide

Model	Sensitive components	Cable length	Product number
KTS120-4L	NTC 10K 3435	3m	04300520160000
KTS120-4K		2m	04300520170000
KTS120-4P		0.5m	04300520320000
KTS120-1L	PT100	3m	04300530160000
KTS120-1K		2m	04300530170000
KTS120-1P		0.5m	04300530320000
KTS120-2L	PT1000	3m	04300540160000
KTS120-2K		2m	04300540170000
KTS120-2P		0.5m	04300540320000
KTS120-3L	NTC 10K 3950	3m	04300550160000
KTS120-3K		2m	04300550170000
KTS120-3P		0.5m	04300550320000
KTS120-5L	NTC 1K	3m	04300560160000
KTS120-5K		2m	04300560170000
KTS120-5P		0.5m	04300560320000
KTS120-6L	NTC 2K	3m	04300570160000
KTS120-6K		2m	04300570170000
KTS120-6P		0.5m	04300570320000



## Description

KTS130 series cable sensor is a low-cost temperature sensor specially designed for temperature measurement in various working environments. It can measure the temperature in air ducts and liquid pipes through different installation and fixing accessories.

## Dimension (mm)

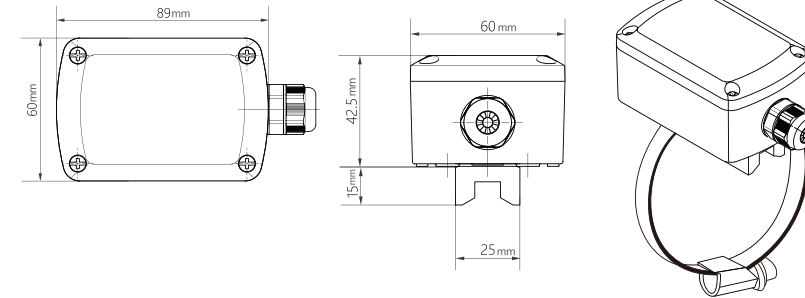

## Accessory Dimension drawing

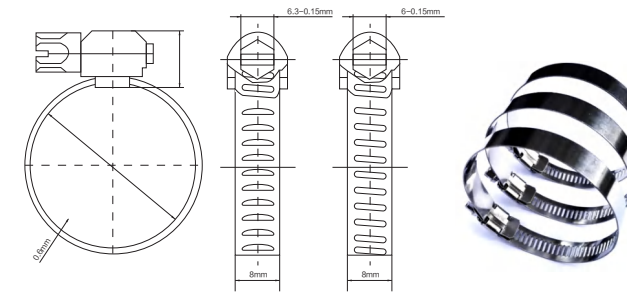

## Features

- Temperature range from -40 to +200
- Resistance output
- Standard precision, see attribute parameter table
- Protection class: IP65/NEMA4

## Application

KTS110 temperature sensor for temperature measurement in heating, ventilation and air conditioning systems.

## Technical Data

Model	KTS130
Temperature sensitive element	PT100 Class A sensitivity $\pm (0.15+0.002t)$
	PT 1000 Class A sensitivity $\pm (0.15+0.002t)$
	NTC 10k B3950 sensitivity $B:3989K \pm 1\%$
	NTC 10k B3435 sensitivity $B:3435K \pm 1\%$
	NTC 1k sensitivity $B:3500K \pm 1\%$
Response time	<1min
Component connection	2 wire
Media	Air or liquid
Operating temperature	-40 ... +70°C
Storage temperature	-30 ... +70°C
Measurement range	-40 ... +200°C
Housing material	PC&ABS, UL94-V0
Protection class	IP65/NEMA 4
Cable gland	M16*1.5

Model	Material	Max working temperature	Applicable pipe diameter
S-250MM	Stainless steel	300°C	250-400mm
S-400MM			400-600mm
S-600MM			600-800mm
S-800MM			800-1000mm
S-1000MM			1000-1600mm



# KTS130 Temperature Sensor

# KTP110 Temperature Sensor

## Ordering Guide

Model	Sensitive components	Clamp model	Product number
KTS130-4V	NTC 10K 3435	250mm	04310520330000
KTS130-4W		400mm	04310520340000
KTS130-4X		600mm	04310520350000
KTS130-4Y		800mm	04310520360000
KTS130-4Z		1000mm	04310520370000
KTS130-1V	PT100	250mm	04310530330000
KTS130-1W		400mm	04310530340000
KTS130-1X		600mm	04310530350000
KTS130-1Y		800mm	04310530360000
KTS130-1Z	1000mm	04310530370000	
KTS130-2V	PT1000	250mm	04310540330000
KTS130-2W		400mm	04310540340000
KTS130-2X		600mm	04310540350000
KTS130-2Y		800mm	04310540360000
KTS130-2Z	1000mm	04310540370000	
KTS130-3V	NTC 10K 3950	250mm	04310550330000
KTS130-3W		400mm	04310550340000
KTS130-3X		600mm	04310550350000
KTS130-3Y		800mm	04310550360000
KTS130-3Z	1000mm	04310550370000	
KTS130-5V	NTC 1K	250mm	04310560330000
KTS130-5W		400mm	04310560340000
KTS130-5X		600mm	04310560350000
KTS130-5Y		800mm	04310560360000
KTS130-5Z	1000mm	04310560370000	
KTS130-6V	NTC 2K	250mm	04310570330000
KTS130-6W		400mm	04310570340000
KTS130-6X		600mm	04310570350000
KTS130-6Y		800mm	04310570360000
KTS130-6Z	1000mm	04310570370000	



## Description

KTP110 resistive temperature sensor passive output, with aluminum connector and straight protective tube, pipeline temperature sensor is used to detect the temperature in liquid or gaseous medium; used in pipelines, heating engineering, compact district heating stations, cold Hot water system, oil and lubrication circulation system, machine fields of mechanical and plant engineering.

## Technical Data

Model	KTP110	
Temperature Sensor	Element	Standard resistance
	NTC10K B3435	R <sub>25</sub> : 10KΩ±1%
	Pt100	R <sub>0</sub> : 100Ω
Component connection	Pt1000	R <sub>0</sub> : 1000Ω
	2 wire	
Size	4 wire (optional)	
	See dimension drawing	
Connector	Aluminum	
	Ambient temperature -20 ... +100	
Protective tube	SS316	
	Φ: 6mm	
Housing protection	Insertion length ( EL ) 50mm - 400mm ( see table )	
	IP54	
Operating temperature	-35 ... +150	
Storage temperature	-30 ... +70	
Humidity	<95% RH ,no precipitation air	
Accessory	See table	
F-06	Mounting flange	
	Galvanized steel	
	Φ: 32mm	
A-B/xx	Max temperature : 700	
	Immersion socket, brass, nickel -plated	
	Φ: 8mm	
A-5xx	Max temperature : 150	
	Max pressure : 10bar	
	Immersion sleeve, stainless steel	
A-5xx	Φ: 8mm	
	Max temperature : 600	
	Max pressure : 40bar	

# KTP110 Temperature Sensor

# KTP110 Temperature Sensor

## Dimension (mm)

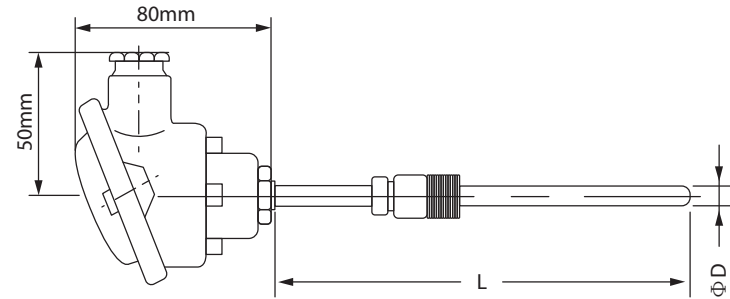

## Accessory Dimension drawing

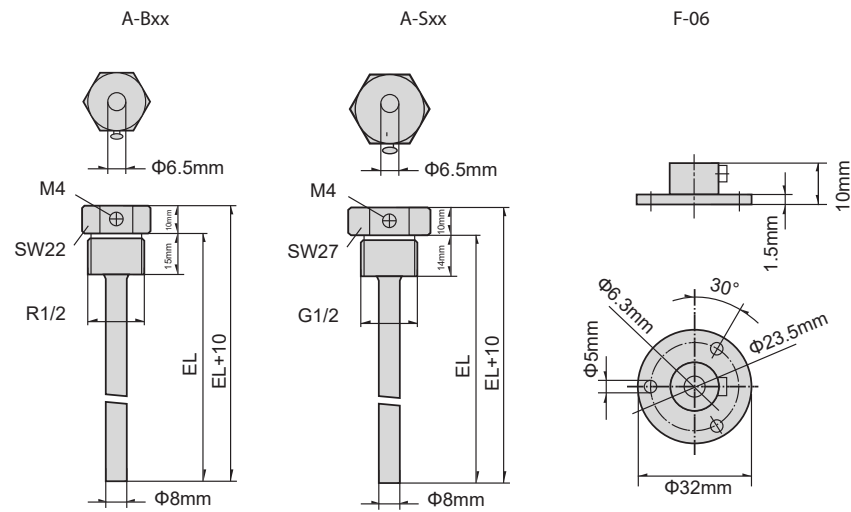

## Accessory

Model	Immersion sleeve diameter	Material	Pmax	Tmax	Insertion length (EL)
A-B 50MM	8mm	Nickel-plated brass	40bar	150°C	50mm
A-B 100MM					100mm
A-B 150MM					150mm
A-B 200MM					200mm
A-B 250MM					250mm
A-B 300MM					300mm
A-B 350MM					350mm
A-B 400MM					400mm

Note: with neck tube(90mm)

Model	Immersion sleeve diameter	Material	Pmax	Tmax	Insertion length (EL)
A-S 50MM	8mm	Nickel-plated brass	40bar	600°C	50mm
A-S 100MM					100mm
A-S 150MM					150mm
A-S 200MM					200mm
A-S 250MM					250mm
A-S 300MM					300mm
A-S 350MM					350mm
A-S 400MM					400mm

Note: with neck tube(90mm)

Model	Diameter	Tube gland	Tmax	Material
F-06	32mm	6.3mm	700°C	Galvanized steel

Note: with neck tube(90mm)

# KTP110 Temperature Sensor

## Ordering Guide

Model	Sensitive components	Probe length	Wiring	Product number
KTP110-2EJ	NTC 10K	50mm	2 wire	04250520191300
KTP110-3EJ			3 wire	04250520191400
KTP110-4EJ			4 wire	04250520191500
KTP110-2EK			2 wire	04250520201300
KTP110-3EK		3 wire	04250520201400	
KTP110-4EK		4 wire	04250520201500	
KTP110-2EL		100mm	2 wire	04250520211300
KTP110-3EL			3 wire	04250520211400
KTP110-4EL			4 wire	04250520211500
KTP110-2EM			2 wire	04250520221300
KTP110-3EM		150mm	3 wire	04250520221400
KTP110-4EM			4 wire	04250520221500
KTP110-2EN			2 wire	04250520231300
KTP110-3EN			3 wire	04250520231400
KTP110-4EN		4 wire	04250520231500	
KTP110-2EO		200mm	2 wire	04250520251300
KTP110-3EO			3 wire	04250520251400
KTP110-4EO			4 wire	04250520251500
KTP110-2EP			2 wire	04250520251300
KTP110-3EP		250mm	3 wire	04250520251400
KTP110-4EP			4 wire	04250520251500
KTP110-2FJ			2 wire	04250530191300
KTP110-3FJ			3 wire	04250530191400
KTP110-4FJ		4 wire	04250530191500	
KTP110-2FK	300mm	2 wire	04250530201300	
KTP110-3FK		3 wire	04250530201400	
KTP110-4FK		4 wire	04250530201500	
KTP110-2FL		2 wire	04250530211300	
KTP110-3FL	150mm	3 wire	04250530211400	
KTP110-4FL		4 wire	04250530211500	
KTP110-2FM		2 wire	04250530221300	
KTP110-3FM		200mm	3 wire	04250530221400
KTP110-4FM	4 wire		04250530221500	
KTP110-2FN	2 wire		04250530231300	
KTP110-3FN	250mm		3 wire	04250530231400
KTP110-4FN		4 wire	04250530231500	
KTP110-2FO		2 wire	04250530251300	
KTP110-3FO		300mm	3 wire	04250530251400
KTP110-4FO	4 wire		04250530251500	
KTP110-2FP	2 wire		04250530251300	
KTP110-3FP	400mm		3 wire	04250530251400
KTP110-4FP		4 wire	04250530251500	
KTP110-2GJ		2 wire	04250540191300	
KTP110-3GJ		50mm	3 wire	04250540191400
KTP110-4GJ	4 wire		04250540191500	
KTP110-2GK	2 wire		04250540201300	
KTP110-3GK	100mm		3 wire	04250540201400
KTP110-4GK		4 wire	04250540201500	
KTP110-2GL		2 wire	04250540211300	
KTP110-3GL		150mm	3 wire	04250540211400
KTP110-4GL	4 wire		04250540211500	
KTP110-2GM	2 wire		04250540221300	
KTP110-3GM	200mm		3 wire	04250540221400
KTP110-4GM		4 wire	04250540221500	
KTP110-2GN		2 wire	04250540231300	
KTP110-3GN		250mm	3 wire	04250540231400
KTP110-4GN	4 wire		04250540231500	
KTP110-2GO	2 wire		04250540251300	
KTP110-3GO	300mm		3 wire	04250540251400
KTP110-4GO		4 wire	04250540251500	
KTP110-2GP		2 wire	04250540251300	
KTP110-3GP		400mm	3 wire	04250540251400
KTP110-4GP	4 wire		04250540251500	



## Flexible and reliable temperature measurement device

Keram Controls temperature sensors cover active and passive series, and the active series provide range setting and switching to meet various measurement needs. A variety of installation types, novel and convenient installation methods to meet all typical applications.



## Description

KTT100 series wall-mounted transmitter is a low-cost temperature transmitter designed for temperature measurement in the field of HVAC. It is suitable for building automatic control system (BA system) of commercial buildings and other conventional buildings.

IP65 protection level is convenient for outdoor measurement at the same time; its output has 4-20mA, 0-10V and RS485.

## Features

- Temperature range from -40 to +200
- 4-20mA, 0-10V, RS-485 output
- Standard accuracy  $\pm 0.3$
- Protection class: IP65/NEMA4

## Application

KTT100 temperature sensor for temperature measurement in heating, ventilation and air conditioning systems.

## Technical Data

Model	KTT100
Accuracy	$\pm 0.3^{\circ}\text{C}$ @20 $^{\circ}\text{C}$
Response time	< 1min
Repeat stability	$\pm 0.01\%$ at FS/year
Media	Air and neutral gases
Operating temperature	-40 $^{\circ}\text{C}$ ... +70 $^{\circ}\text{C}$
Storage temperature	-30 $^{\circ}\text{C}$ ... +70 $^{\circ}\text{C}$
Measurement range	-40 $^{\circ}\text{C}$ ... +200 $^{\circ}\text{C}$
Power consumption	< 1.5W
Power supply	24VAC/DC $\pm 10\%$
Output	4-20mA (2 wire)
	4-20mA (3 wire)
	0~5 / 0~10VDC (3 wire)
	RS-485
Housing material	PC&ABS, UL94V-0
Protection class	IP65/NEMA4
Cable gland	M16*1.5

## Dimension (mm)

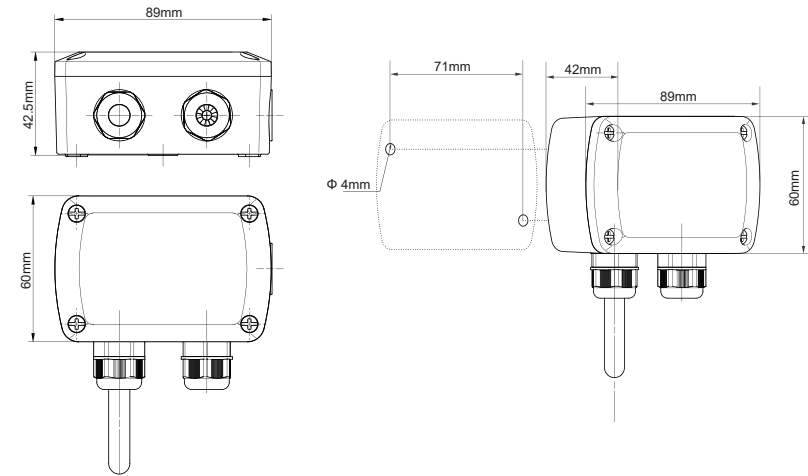

## Measurement Range Adjustment

ON	ON	ON	ON	ON
1 2 3	1 2 3	1 2 3	1 2 3	1 2 3
-40 ... +70 $^{\circ}\text{C}$	0 ... +50 $^{\circ}\text{C}$	0 ... +100 $^{\circ}\text{C}$	-30 ... +200 $^{\circ}\text{C}$	-40 ... +140 $^{\circ}\text{C}$

**!** Note: During the installation process of the device, the device cannot be powered on; you can set it by the DIP switch; after the device is assembled, it can be connected to the power supply.

## Ordering Guide

Model	Output	Sensitive components	Product number
KTT100-E	4-20mA (2-wire)	PT1000	04320000380000
KTT100-F	4-20mA (3-wire)		04320000390000
KTT100-G	0-10V		04320000400000
KTT100-H	RS485		04320000410000



### Description

The KTT110 series duct mount transmitter is a low-cost temperature transmitter designed for temperature measurement in the HVAC field; it is suitable for building automation systems (BA systems) in commercial buildings and other conventional buildings. IP65 degree of protection facilitates simultaneous outdoor measurements; the transmitter output has 4-20mA, 0-10V and RS-485.

### Features

- Temperature range from -40 to +200
- 4-20mA, 0-10V, RS-485 output
- Standard accuracy  $\pm 0.3$
- Protection class: IP65/NEMA4

### Application

KTT100 temperature sensor for temperature measurement in heating, ventilation and air conditioning systems.

### Technical Data

Model	KTT110
Accuracy	$\pm 0.3^{\circ}\text{C}@20^{\circ}\text{C}$
Response time	<1 min, in 3m/s(590ft/min) air duct; <30 s, testing the liquid in pipe
Repeat stability	$\pm 0.01\%$ at FS/year
Media	Air and liquid
Operating temperature	-40 ... +110°C(air duct)/-40 ... +200°C (liquid duct)
Storage temperature	-30°C ... +70°C
Measurement range	-40°C ... +200°C
Working & storage humidity range	5% RH ... 95% RH, non-condensing
Power consumption	< 1.5W
Power supply	24VAC/DC $\pm 10\%$
Output	4-20mA (2 wire)
	4-20mA (3 wire)
	0~5/0~10VDC (3 wire)
	RS-485
Housing material	PC& ABS, UL94V-0
Protection class	IP65/NEMA4
Cable gland	M16*1.5

### Dimensions (mm)

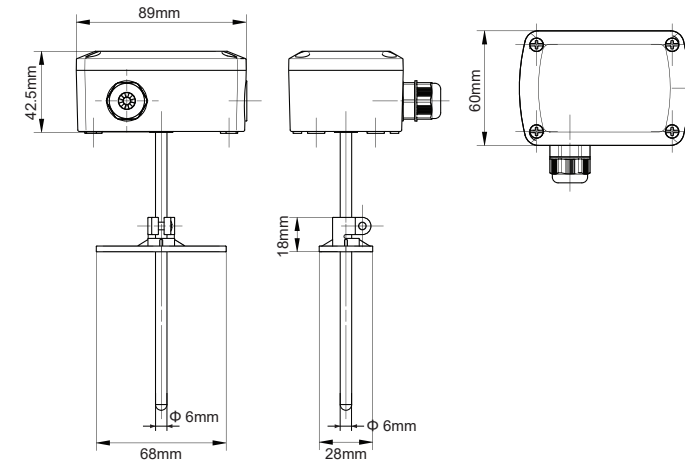

### Measurement Range Adjustment

ON	ON	ON	ON	ON
1 2 3	1 2 3	1 2 3	1 2 3	1 2 3
-40 ... +70°C	0 ... +50°C	0 ... +100°C	-30 ... +200°C	-40 ... +140°C



Note: During the installation process of the device, the device cannot be powered on; you can set it by the DIP switch; after the device is assembled, it can be connected to the power supply.

### Accessory Dimension drawing

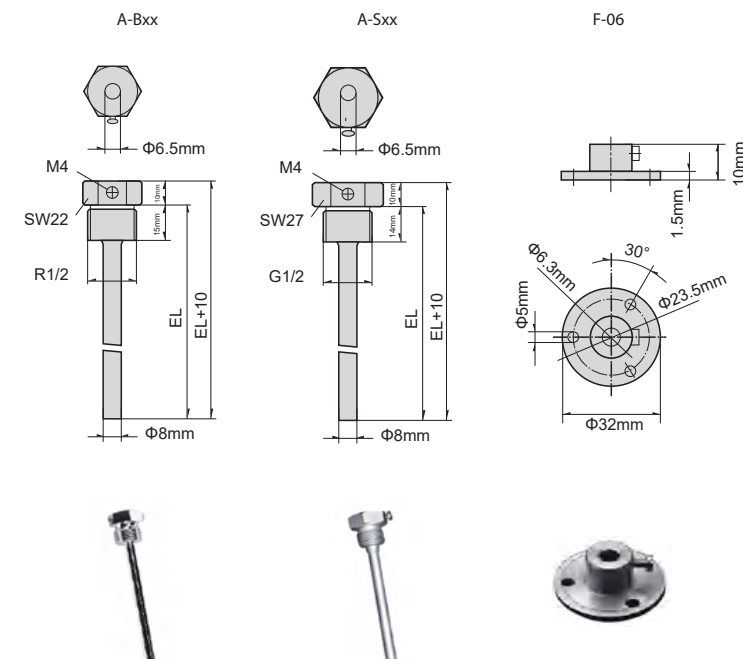

# KTT110 Temperature Transmitter

# KTT120 Temperature Transmitter

## Accessory

Model	Immersion sleeve diameter	Material	Maximum pressure	Max working temperature	Insertion length (EL)
A-B 50MM	8mm	Nickel-plated brass	10bar	150°C	50mm
A-B 100MM					100mm
A-B 150MM					150mm
A-B 200MM					200mm
A-B 250MM					250mm
A-B 300MM					300mm
A-B 350MM					350mm
A-B 400MM					400mm

Note: with neck tube(90mm)

Model	Immersion sleeve diameter	Material	Maximum pressure	Max working temperature	Insertion length (EL)
A-S 50/90MM	8mm	stainless steel	40bar	600°C	50mm
A-S 100/90MM					100mm
A-S 150/90MM					150mm
A-S 200/90MM					200mm
A-S 250/90MM					250mm
A-S 300/90MM					300mm

Note: with neck tube(90mm)

Model	Diameter	Maximum	Max working temperature	Material
F-06	32mm	6.3mm	700°C	Galvanized steel

Note: with neck tube(90mm)

## Ordering Guide

Model	Output	Sensitive components	Probe length	Product number
KTT110-AE	4-20mA (2 wire)	PT1000	65mm	04320300380000
KTT110-AF	4-20mA (3 wire)			04320300390000
KTT110-AG	0-10V			04320300400000
KTT110-AH	RS485			04320300410000
KTT110-BE	4-20mA (2 wire)		120mm	04320310380000
KTT110-BF	4-20mA (3 wire)			04320310390000
KTT110-BG	0-10V			04320310400000
KTT110-BH	RS485			04320310410000
KTT110-CE	4-20mA (2 wire)		150mm	04320210380000
KTT110-CF	4-20mA (3 wire)			04320210390000
KTT110-CG	0-10V			04320210400000
KTT110-CH	RS485			04320210410000
KTT110-DE	4-20mA (2 wire)		300mm	04320240380000
KTT110-DF	4-20mA (3 wire)			04320240390000
KTT110-DG	0-10V			04320240400000
KTT110-DH	RS485			04320240410000



## Description

KTT120 series cable transmitter is a low-cost temperature transmitter specially designed for temperature measurement, suitable for temperature measurement in various working environments; it can measure the temperature in air ducts and liquid pipes in different installations and Fixed accessories; the transmitter output has 4-20mA, 0-10V and RS-485.

## Features

- Temperature range from -40 to +200
- 4-20mA, 0-10V, RS-485 output
- Standard accuracy  $\pm 0.3$
- Protection class: IP65/NEMA4

## Application

KTT100 temperature sensor for temperature measurement in heating, ventilation and air conditioning systems.

## Technical Data

Model	KTT120
Accuracy	$\pm 0.3^{\circ}\text{C}@20^{\circ}\text{C}$
Response time	<1min, in 3m/s (590ft/min) In the air duct / <30s, Measure liquids in pipes
Repeat stability	$\pm 0.01\%$ at FS/year
Media	Air and liquid
Operating temperature	-30 ... +200°C (probe)
Storage temperature	-30 ... +70°C (body)
Measurement range	-40°C ... +200°C
Working & storage humidity range	5% RH ... 95% RH, non-condensing
Power consumption	< 1.5W
Power supply	24VAC/DC $\pm 10\%$
Output	4-20mA (2 wire)
	4-20mA (3 wire)
	0-5/0~10VDC (3 wire)
	RS-485
Housing material	PC& ABS, UL94V-0
Protection class	IP65/NEMA4
Cable gland	M16*1.5

# KTT120 Temperature Transmitter

# KTT130 Temperature Transmitter

## Dimensions (mm)

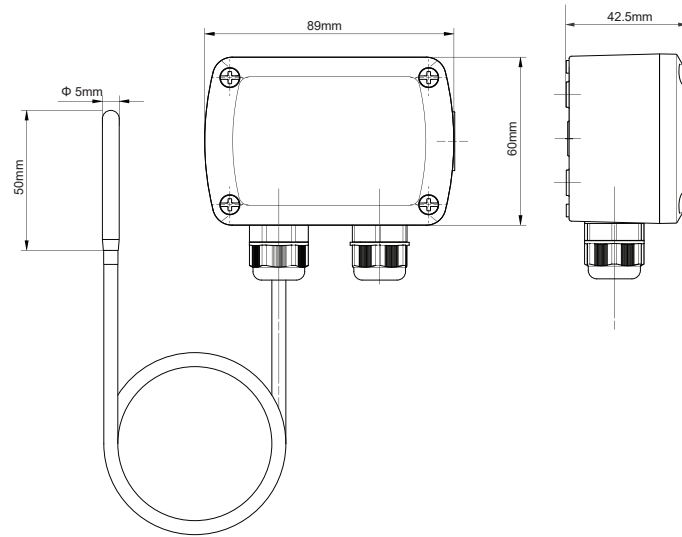

## Measurement Range Adjustment

ON	ON	ON	ON	ON
1 2 3	1 2 3	1 2 3	1 2 3	1 2 3
-40 ... +70°C	0 ... +50°C	0 ... +100°C	-30 ... +200°C	-40 ... +140°C



Note: During the installation process of the device, the device cannot be powered on; you can set it by the DIP switch; after the device is assembled, it can be connected to the power supply.

## Ordering Guide

Model	Output	Sensitive components	Probe length	Product number
KTT120-LE	4-20mA ( 2 wire )	PT1000	3m	04340000160100
KTT120-KE			2m	04340000160200
KTT120-PE			0.5m	04340000160300
KTT120-LF	4-20mA (3 wire)		3m	04340000160400
KTT120-KF			2m	04340000170100
KTT120-PF			0.5m	04340000170200
KTT120-LG	0-10V		3m	04340000170300
KTT120-KG			2m	04340000170400
KTT120-PG			0.5m	04340000320100
KTT120-LH	RS485		3m	04340000320200
KTT120-KH			2m	04340000320300
KTT120-PH			0.5m	04340000320400



## Description

KTT130 series bundled transmitter is a low-cost temperature transmitter specially designed for pipe surface temperature measurement. Suitable for temperature measurement in various applications. The transmitter output mode has standard 4-20mA, 0-10V and RS-485.

## Features

- Temperature range from -40 to +200
- 4-20mA, 0-10V, RS-485 output
- Standard accuracy  $\pm 0.3$
- Protection class: IP65/NEMA4

## Application

KTT100 temperature sensor for temperature measurement in heating, ventilation and air conditioning systems.

## Technical Data

Model	KTT130
Accuracy	$\pm 0.3^{\circ}\text{C}@20^{\circ}\text{C}$
Response time	<1min
Repeat stability	Air and liquid
Media	$\pm 0.01\%$ at FS/year
Operating temperature	-30 ... +70°C
Storage temperature	-30°C ... +70°C
Measurement range	-40°C ... +140°C
Working & storage humidity range	5% RH ... 95% RH, non-condensing
Power consumption	< 1.5W
Power supply	24VAC/DC $\pm 10\%$
Output	4-20mA ( 2 wire )
	4-20mA ( 3 wire )
	0-5/0-10VDC ( 3 wire )
Housing material	PC& ABS, UL94V-0
Protection class	IP65/NEMA4
Cable gland	M16*1.5

## Dimension (mm)

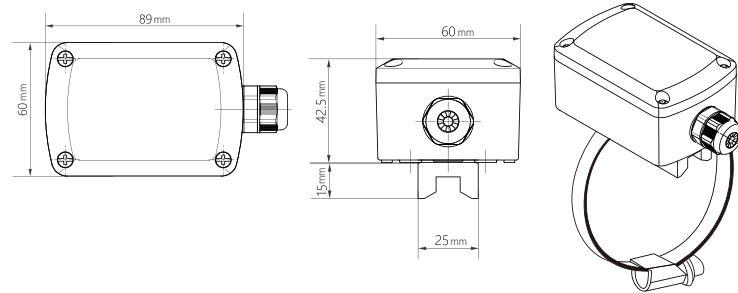

## Measurement Range Adjustment

ON	ON	ON	ON	ON
1 2 3	1 2 3	1 2 3	1 2 3	1 2 3
-40 ... +70°C	0 ... +50°C	0 ... +100°C	-30 ... +200°C	-40 ... +140°C

## Output Setting (3 wire model)

ON	ON	ON
4 5	4 5	4 5
0-5V	0-10V	4-20mA

**!** Note: During the installation process of the device, the device cannot be powered on; you can set it by the DIP switch; after the device is assembled, it can be connected to the power supply.

## Accessory Dimension drawing

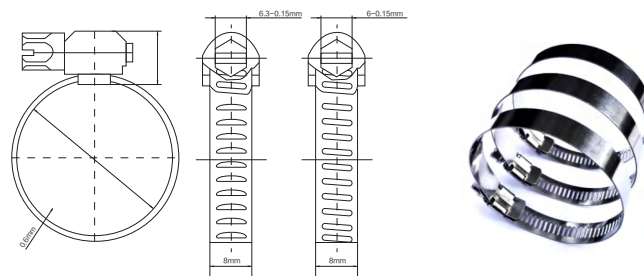

Model	Material	Max working temperature	Applicable pipe diameter
S-250MM	Stainless steel	300°C	250-400mm
S-400MM			400-600mm
S-600MM			600-800mm
S-800MM			800-1000mm
S-1000MM			1000-1600mm

## Ordering Guide

Model	Output	Sensitive components	Clamp model	Product number
KTT130-VE	4-20mA (2 wire)	PT1000	250mm	04350000330100
KTT130-VF	4-20mA (3 wire)			04350000330200
KTT130-VG	0-10V			04350000330300
KTT130-VH	RS485			04350000330400
KTT130-WE	4-20mA (2 wire)		400mm	04350000340100
KTT130-WF	4-20mA (3 wire)			04350000340200
KTT130-WG	0-10V			04350000340300
KTT130-WH	RS485			04350000340400
KTT130-XE	4-20mA (2 wire)		600mm	04350000350100
KTT130-XF	4-20mA (3 wire)			04350000350200
KTT130-XG	0-10V			04350000350300
KTT130-XH	RS485			04350000350400
KTT130-YE	4-20mA (2 wire)		800mm	04350000360100
KTT130-YF	4-20mA (3 wire)			04350000360200
KTT130-YG	0-10V			04350000360300
KTT130-YH	RS485			04350000360400
KTT130-ZE	4-20mA (2 wire)		1000mm	04350000370100
KTT130-ZF	4-20mA (3 wire)			04350000370200
KTT130-ZG	0-10V			04350000370300
KTT130-ZH	RS485			04350000370400





# KAV110 Wind Speed Transmitter



## Description

KAV110 series ducted air velocity transmitter is an air velocity transmitter specially designed for obtaining accurate measurement results in building control applications and various ventilation systems.

KAV110 series wind speed transmitter adopts VTQ type wind speed sensitive element. The structural characteristics of the product shell and the mounting flange equipped in the box are convenient for quick installation and replacement on site.

## Features

- HVAC
- Filter pressure drop monitoring
- Flue gas treatment
- Suitable for textile, chemical industry, aviation, power plant, coal mine
- Ducted air flow, variable air volume systems, biological safety cabinets
- Small wind speed measurement in operating room, clean room, biological laboratory, electronics, medical environment and others

## Technical Data

Model	KAV110
Power supply	16-24VAC or VDC
Output	4-20mA/ 0-5V/ 0-10V/ RS-485
Operating temperature	-5 ... +70°C
Storage temperature	-20 ... +70°C
Humidity range	0 ... 90%RH
Measuring range	1~30m/s
Accuracy	0.2%FS
Working frequency	50Hz
Maximum wind speed/flow speed	30m/s
Electromagnetic compatibility	EN61326-1 (Industrial environment)
Housing material	ABS
Protection class	IP65/ NEMA4
Cable gland	M16*1.5

## Dimension (mm)

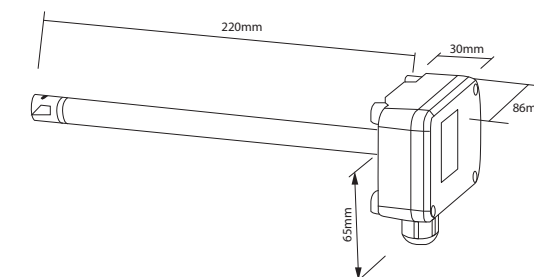
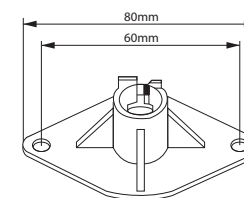

## Stable & high-precision wind speed and air volume measurement equipment

Measuring air speed and volume in ventilation and air conditioning systems helps maintain good air quality and efficient circulation in buildings.

Maintaining good air circulation in buildings is critical to maintaining the indoor environment, Especially in some specific environments, such as computer room, kinetic energy machine room, power equipment room and so on.



# KAV110 Wind Speed Transmitter

# KAV120 Wind Speed Transmitter

## Ordering Guide

■ Display × No display

Model	Output	Range	Display	Product number
KAV110-1DE	4-20mA (2 wire)	0-1m/s	■	02090320010100
KAV110-2DE		0-2m/s		02090330010100
KAV110-3DE		0-5m/s		02090340010100
KAV110-4DE		0-10m/s		02090350010100
KAV110-5DE		0-15m/s		02090360010100
KAV110-6DE		0-20m/s		02090370010100
KAV110-7DE		0-30m/s		02090380010100
KAV110-1-E		0-1m/s	×	02090320020100
KAV110-2-E		0-2m/s		02090330020100
KAV110-3-E		0-5m/s		02090340020100
KAV110-4-E		0-10m/s		02090350020100
KAV110-5-E		0-15m/s		02090360020100
KAV110-6-E		0-20m/s		02090370020100
KAV110-7-E		0-30m/s		02090380020100
KAV110-1DF	4-20mA (3 wire)	0-1m/s	■	02090320010200
KAV110-2DF		0-2m/s		02090330010200
KAV110-3DF		0-5m/s		02090340010200
KAV110-4DF		0-10m/s		02090350010200
KAV110-5DF		0-15m/s		02090360010200
KAV110-6DF		0-20m/s		02090370010200
KAV110-7DF		0-30m/s		02090380010200
KAV110-1-F		0-1m/s	×	02090320020200
KAV110-2-F		0-2m/s		02090330020200
KAV110-3-F		0-5m/s		02090340020200
KAV110-4-F		0-10m/s		02090350020200
KAV110-5-F		0-15m/s		02090360020200
KAV110-6-F		0-20m/s		02090370020200
KAV110-7-F		0-30m/s		02090380020200
KAV110-1DG	0-10V	0-1m/s	■	02090320010300
KAV110-2DG		0-2m/s		02090330010300
KAV110-3DG		0-5m/s		02090340010300
KAV110-4DG		0-10m/s		02090350010300
KAV110-5DG		0-15m/s		02090360010300
KAV110-6DG		0-20m/s		02090370010300
KAV110-7DG		0-30m/s		02090380010300
KAV110-1-G		0-1m/s	×	02090320020300
KAV110-2-G		0-2m/s		02090330020300
KAV110-3-G		0-5m/s		02090340020300
KAV110-4-G		0-10m/s		02090350020300
KAV110-5-G		0-15m/s		02090360020300
KAV110-6-G		0-20m/s		02090370020300
KAV110-7-G		0-30m/s		02090380020300
KAV110-1DH	RS485	0-1m/s	■	02090320010400
KAV110-2DH		0-2m/s		02090330010400
KAV110-3DH		0-5m/s		02090340010400
KAV110-4DH		0-10m/s		02090350010400
KAV110-5DH		0-15m/s		02090360010400
KAV110-6DH		0-20m/s		02090370010400
KAV110-7DH		0-30m/s		02090380010400
KAV110-1-H		0-1m/s	×	02090320020400
KAV110-2-H		0-2m/s		02090330020400
KAV110-3-H		0-5m/s		02090340020400
KAV110-4-H		0-10m/s		02090350020400
KAV110-5-H		0-15m/s		02090360020400
KAV110-6-H		0-20m/s		02090370020400
KAV110-7-H		0-30m/s		02090380020400



## Description

KAV120 series wind speed transmitter adopts high temperature resistant and corrosion resistant material shell, which can achieve stable and reliable performance even in harsh working environment. Compared with traditional speed sensors, better stability can be obtained, faster and more accurate small air volume measurement and accuracy can be guaranteed, wide turndown ratio, full-scale accurate calibration of measurement data through internal microcontroller, linear compensation and The temperature compensation is all digital, resulting in excellent performance of high precision and high resolution.

## Features

- HVAC
- Filter pressure drop monitoring
- Flue gas treatment
- Suitable for textile, chemical industry, aviation, power plant, coal mine Ducted air flow, variable air volume systems, biological safety cabinets
- Small wind speed measurement in operating room, clean room, biological laboratory, electronics, medical environment and other fields

## Technical Data

Model	KAV120
Power supply	16-24VAC or VDC
Output	4-20mA/ 0-5V/ 0-10V/ RS-485
Operating temperature	-5 ... +70°C
Storage temperature	-20 ... +70°C
Humidity range	0 ... 90%RH
Measuring range	1~30m/s
Accuracy	0.2%FS
Working frequency	50Hz
Maximum wind speed/flow speed	30m/s
Electromagnetic compatibility	EN61326-1 (Industrial environment)
Housing material	ABS
Protection class	IP65/ NEMA4
Cable gland	M16*1.5

## Dimension (mm)

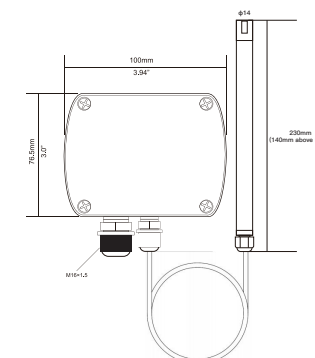

# KAV120 Wind Speed Transmitter

## Ordering Guide

■ Display × No display

Model	Output	Range	Display	Cable length	Product number									
KAV120-1D1ME	4-20mA (2 wire)	0-1m/s	■	1m	02100320010201									
KAV120-2D1ME		0-2m/s			×	02100330010201								
KAV120-3D1ME		0-5m/s				■	02100340010201							
KAV120-4D1ME		0-10m/s					×	02100350010201						
KAV120-5D1ME		0-15m/s						■	02100360010201					
KAV120-6D1ME		0-20m/s							×	02100370010201				
KAV120-7D1ME		0-30m/s								■	02100380010201			
KAV120-1-1ME		0-1m/s	×								02100320020201			
KAV120-2-1ME		0-2m/s									■	02100330020201		
KAV120-3-1ME		0-5m/s				×						02100340020201		
KAV120-4-1ME		0-10m/s										■	02100350020201	
KAV120-5-1ME		0-15m/s						×					02100360020201	
KAV120-6-1ME		0-20m/s											■	02100370020201
KAV120-7-1ME		0-30m/s								×				02100380020201
KAV120-1D1MF	4-20mA (3 wire)	0-1m/s												■
KAV120-2D1MF		0-2m/s			×						02100330010201			
KAV120-3D1MF		0-5m/s									■			
KAV120-4D1MF		0-10m/s					×					02100350010201		
KAV120-5D1MF		0-15m/s										■		
KAV120-6D1MF		0-20m/s							×				02100370010201	
KAV120-7D1MF		0-30m/s											■	
KAV120-1-1MF		0-1m/s	×											02100320020201
KAV120-2-1MF		0-2m/s												■
KAV120-3-1MF		0-5m/s				×					02100340020201			
KAV120-4-1MF		0-10m/s									■			
KAV120-5-1MF		0-15m/s						×				02100360020201		
KAV120-6-1MF		0-20m/s										■		
KAV120-7-1MF		0-30m/s								×			02100380020201	
KAV120-1D1MG	0-10V	0-1m/s		■									02100320010301	
KAV120-2D1MG		0-2m/s			×								02100330010301	
KAV120-3D1MG		0-5m/s											■	02100340010301
KAV120-4D1MG		0-10m/s					×				02100350010301			
KAV120-5D1MG		0-15m/s									■			02100360010301
KAV120-6D1MG		0-20m/s							×			02100370010301		
KAV120-7D1MG		0-30m/s										■		02100380010301
KAV120-1-1MG		0-1m/s	×	02100320020301										
KAV120-2-1MG		0-2m/s		■										02100330020301
KAV120-3-1MG		0-5m/s				×							02100340020301	
KAV120-4-1MG		0-10m/s											■	02100350020301
KAV120-5-1MG		0-15m/s						×			02100360020301			
KAV120-6-1MG		0-20m/s									■			02100370020301
KAV120-7-1MG		0-30m/s								×		02100380020301		
KAV120-1D1MH	RS485	0-1m/s										■		02100320010401
KAV120-2D1MH		0-2m/s		×	02100330010401									
KAV120-3D1MH		0-5m/s			■									02100340010401
KAV120-4D1MH		0-10m/s					×						02100350010401	
KAV120-5D1MH		0-15m/s											■	02100360010401
KAV120-6D1MH		0-20m/s							×		02100370010401			
KAV120-7D1MH		0-30m/s									■			02100380010401
KAV120-1-1MH		0-1m/s	×									02100320020401		
KAV120-2-1MH		0-2m/s										■		02100330020401
KAV120-3-1MH		0-5m/s			×	02100340020401								
KAV120-4-1MH		0-10m/s				■								02100350020401
KAV120-5-1MH		0-15m/s						×					02100360020401	

## Ordering Guide

■ Display × No display

Model	Output	Range	Display	Cable length	Product number									
KAV120-6-1MH	RS485	0-20m/s	×	1m	02100370020401									
KAV120-7-1MH		0-30m/s			■	02100380020401								
KAV120-1D3ME		0-1m/s				■	02100320010102							
KAV120-2D3ME		0-2m/s					×	02100330010102						
KAV120-3D3ME		0-5m/s						■	02100340010102					
KAV120-4D3ME		0-10m/s							×	02100350010102				
KAV120-5D3ME		0-15m/s								■	02100360010102			
KAV120-6D3ME		0-20m/s	×								02100370010102			
KAV120-7D3ME		0-30m/s									■	02100380010102		
KAV120-1-3ME		0-1m/s				×						02100320020102		
KAV120-2-3ME		0-2m/s										■	02100330020102	
KAV120-3-3ME		0-5m/s						×					02100340020102	
KAV120-4-3ME		0-10m/s											■	02100350020102
KAV120-5-3ME		0-15m/s								×				02100360020102
KAV120-6-3ME	0-20m/s	■												02100370020102
KAV120-7-3ME	0-30m/s				×						02100380020102			
KAV120-1D3MF	4-20mA (3 wire)										0-1m/s			■
KAV120-2D3MF							0-2m/s				×	02100330010202		
KAV120-3D3MF							0-5m/s					■		
KAV120-4D3MF							0-10m/s		×				02100350010202	
KAV120-5D3MF							0-15m/s						■	
KAV120-6D3MF		0-20m/s	×				02100370010202							
KAV120-7D3MF		0-30m/s					■							
KAV120-1-3MF		0-1m/s				×								02100320020202
KAV120-2-3MF		0-2m/s												■
KAV120-3-3MF		0-5m/s						×				02100340020202		
KAV120-4-3MF		0-10m/s										■		
KAV120-5-3MF		0-15m/s								×			02100360020202	
KAV120-6-3MF		0-20m/s		■									02100370020202	
KAV120-7-3MF		0-30m/s			×		02100380020202							
KAV120-1D3MG	0-10V	0-1m/s					■						02100320010302	
KAV120-2D3MG		0-2m/s									×		02100330010302	
KAV120-3D3MG		0-5m/s											■	02100340010302
KAV120-4D3MG		0-10m/s							×			02100350010302		
KAV120-5D3MG		0-15m/s										■		02100360010302
KAV120-6D3MG		0-20m/s	×	02100370010302										
KAV120-7D3MG		0-30m/s		■										02100380010302
KAV120-1-3MG		0-1m/s				×	02100320020302							
KAV120-2-3MG		0-2m/s					■							02100330020302
KAV120-3-3MG		0-5m/s						×					02100340020302	
KAV120-4-3MG		0-10m/s											■	02100350020302
KAV120-5-3MG		0-15m/s								×		02100360020302		
KAV120-6-3MG		0-20m/s										■		02100370020302
KAV120-7-3MG		0-30m/s		×	02100380020302									
KAV120-1D3MH	RS485	0-1m/s			■									02100320010402
KAV120-2D3MH		0-2m/s					×				02100330010402			
KAV120-3D3MH		0-5m/s									■			02100340010402
KAV120-4D3MH		0-10m/s							×				02100350010402	
KAV120-5D3MH		0-15m/s											■	02100360010402
KAV120-6D3MH		0-20m/s	×									02100370010402		
KAV120-7D3MH		0-30m/s										■		02100380010402
KAV120-1-3MH		0-1m/s			×	02100320020402								
KAV120-2-3MH		0-2m/s				■								02100330020402
KAV120-3-3MH		0-5m/s						×			02100340020402			

# KAV120 Wind Speed Transmitter

## Ordering Guide

■ Display × No display

Model	Output	Range	Display	Cable length	Product number
KAV120-4-3MH	RS485	0-10m/s	×	3m	02100350020402
KAV120-5-3MH		0-15m/s			02100360020402
KAV120-6-3MH		0-20m/s			02100370020402
KAV120-7-3MH		0-30m/s			02100380020402
KAV120-1D5ME	4-20mA (2 wire)	0-1m/s	■	5m	02100320010103
KAV120-2D5ME		0-2m/s			02100330010103
KAV120-3D5ME		0-5m/s			02100340010103
KAV120-4D5ME		0-10m/s			02100350010103
KAV120-5D5ME		0-15m/s			02100360010103
KAV120-6D5ME		0-20m/s			02100370010103
KAV120-7D5ME		0-30m/s			02100380010103
KAV120-1-5ME		0-1m/s			02100320020103
KAV120-2-5ME		0-2m/s			02100330020103
KAV120-3-5ME		0-5m/s			02100340020103
KAV120-4-5ME		0-10m/s			02100350020103
KAV120-5-5ME		0-15m/s			02100360020103
KAV120-6-5ME		0-20m/s			02100370020103
KAV120-7-5ME		0-30m/s			02100380020103
KAV120-1D5MF	4-20mA (3 wire)	0-1m/s	■	5m	02100320010203
KAV120-2D5MF		0-2m/s			02100330010203
KAV120-3D5MF		0-5m/s			02100340010203
KAV120-4D5MF		0-10m/s			02100350010203
KAV120-5D5MF		0-15m/s			02100360010203
KAV120-6D5MF		0-20m/s			02100370010203
KAV120-7D5MF		0-30m/s			02100380010203
KAV120-1-5MF		0-1m/s			02100320020203
KAV120-2-5MF		0-2m/s			02100330020203
KAV120-3-5MF		0-5m/s			02100340020203
KAV120-4-5MF		0-10m/s			02100350020203
KAV120-5-5MF		0-15m/s			02100360020203
KAV120-6-5MF		0-20m/s			02100370020203
KAV120-7-5MF		0-30m/s			02100380020203
KAV120-1D5MG	0-10V	0-1m/s	■	5m	02100320010303
KAV120-2D5MG		0-2m/s			02100330010303
KAV120-3D5MG		0-5m/s			02100340010303
KAV120-4D5MG		0-10m/s			02100350010303
KAV120-5D5MG		0-15m/s			02100360010303
KAV120-6D5MG		0-20m/s			02100370010303
KAV120-7D5MG		0-30m/s			02100380010303
KAV120-1-5MG		0-1m/s			02100320020303
KAV120-2-5MG		0-2m/s			02100330020303
KAV120-3-5MG		0-5m/s			02100340020303
KAV120-4-5MG		0-10m/s			02100350020303
KAV120-5-5MG		0-15m/s			02100360020303
KAV120-6-5MG		0-20m/s			02100370020303
KAV120-7-5MG		0-30m/s			02100380020303
KAV120-1D5MH	RS485	0-1m/s	■	5m	02100320010403
KAV120-2D5MH		0-2m/s			02100330010403
KAV120-3D5MH		0-5m/s			02100340010403
KAV120-4D5MH		0-10m/s			02100350010403
KAV120-5D5MH		0-15m/s			02100360010403
KAV120-6D5MH		0-20m/s			02100370010403
KAV120-7D5MH		0-30m/s			02100380010403
KAV120-1-5MH		0-1m/s			02100320020403
KAV120-2-5MH		0-2m/s			02100330020403
KAV120-3-5MH		0-5m/s			02100340020403
KAV120-4-5MH		0-10m/s			02100350020403
KAV120-5-5MH		0-15m/s			02100360020403
KAV120-6-5MH		0-20m/s			02100370020403
KAV120-7-5MH		0-30m/s			02100380020403



## Flexible and efficient flow measurement equipment

As a sensor for gas and liquid flow measurement, it is widely used in water supply systems and drainage systems. The flow switch is made of plastic-reinforced glass optical fiber. When the fluid passes through, a magnetic field is generated and drives the reed switch, and then the signal is output.

## Long-term stability

The measuring element is completely isolated from the medium and does not need spring return, so the product has a long service life and good stability.



### Description

KAFS adjustable air flow switch is used to control and monitor the flow of air and non-corrosive gases in ducts, ideal for ducts, air conditioning and air handling systems.

### Application

Control and monitor the flow of air and non corrosive gases in pipes, chambers, and heating, cooling, air conditioning equipment, etc.

### Feature

- New SPDT micro switch to ensure reliable switching function
- Stainless steel paddle
- Cut in and cut out
- Brass lever
- IP65

### Technical Data

Model	KAFS
Operation type	On/Off, Single Stage, SPDT
Flow rate switch	
- cut out	min 1.0 m/ sec, max 8.0m/ sec
- cut in	min 2.5 m/ sec, max 9.2m/ sec
Flow setting adjustment	Internal thread screw
Sensing element	Paddle
Paddle size	3.2 x 6.9 in (80 x 175mm)
Paddle W/ level-length	7.9 in (200mm)
Operating temperature	Air and non-corrosive gases
Paddle material	Stainless steel
Paddle lever material	Brass
Operating temperature	
- Housing	-40°F至 185°F (-40°C至 85°C)
- Paddle	14°F至 185°F (-10°C至 85°C)
Operating temperature	10 ... 90%RH, no condensation
Cable interface	M18
Housing material	ABS+PC
- Color	White
Protection class	IP54
Installation	Duct-mounted
Weight	0.7kg

### Installation

The flow switch should be installed in the pipe or chamber where the paddle can move downward freely. In order to avoid air vortex and paddle instability, the installation position should be in the middle of the distance from upstream to downstream, and the distance should be at least the diameter of the pipe 5 times the size.

Note:



These units are factory calibrated to the minimum shut-off value, if the set point needs to be increased, just adjust the span screw clockwise; due to the risk of breakage at air velocities above 5.0m/s, the paddles must be on the marked side Cutoff, when the

### Electrical Wiring

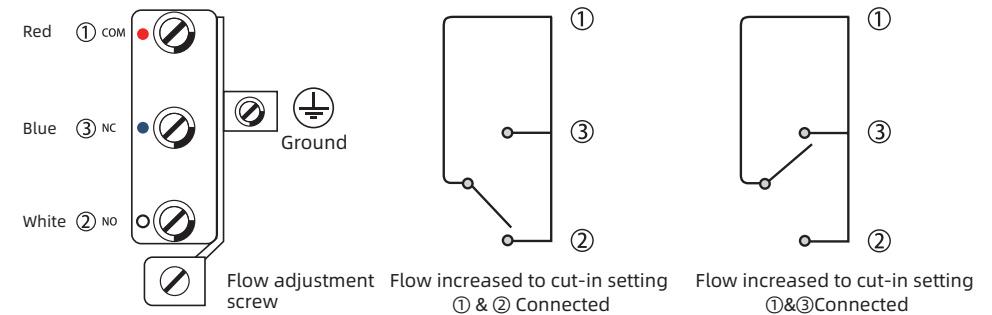

### Dimension (mm)

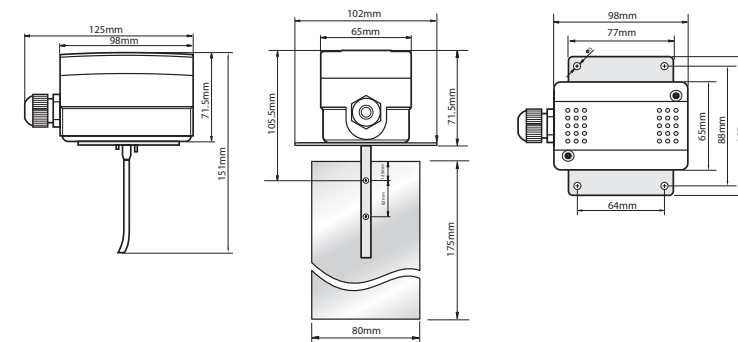

### Ordering Guide

Model	Product number
KAFS	0211000000000

# KWFS Liquid Flow Switch



## Description

KWFS series liquid flow switch are suitable for piping in industrial plants: heating and air conditioning, refrigeration systems and heat pumps; flow control of water and general liquid media.

## Features

- Flow control of water and common media
- New SPDT micro switch to ensure reliable switching function
- 15 (8A) 250VAC rated output value
- IP65
- Adjustable set value
- Stainless steel paddle
- Brass material
- Maximum fluid temperature 120
- Maximum working pressure 13.5Ba

## Application

Applications for controlling and monitoring liquid flow in boilers, pumps, etc. of heating, cooling and air conditioning equipment.

## Technical Data

Operation type	On/Off, Single Stage, SPDT
Output	SPDT ,15(8A) 24/250VAC
Flow	See flow chart
Flow setting adjustment	Internal thread screw
Sensing element	Paddle
Media	Hot, cold, well, pool and sea water, brine or glycol
Materials of parts in contact with fluid	Brass
Paddle material	Stainless steel
Liquid temperature	-20 ... 120
Operating temperature	-40 ... 85
Operating humidity	10 ... 90%RH ,no condensation
Cable interface	M18
Housing material	ABS+PC
Protection class	IP65
Color	white
Weight	1.0Kg

## Model

Mode	Connection
KWFS-1	1/2"-14 NPT
KWFS-2	3/4"-14 NPT
KWFS-3	1" -11 1/2NPT

## Liquid Flow Rate Table

Line Pipe Size(in.)	1	1-1/4	1-1/2	2	2-1/2	3	4	4Z	5	5Z	6	6Z	8	8Z	
Min. flow	Flow increase & connected	4.2 (1.0)	5.8 (1.3)	7.5 (1.7)	13.7 (3.1)	17.6 (4.0)	27.5 (6.2)	64.7 (14.7)	35.2 (8.0)	12.5 (28.4)	57.01 (12.9)	90.0 (43.1)	74.0 (16.8)	374.7 (85.1)	204.7 (46.5)
	Flow decrease & connected	2.5 (0.6)	3.7 (0.8)	5.0 (1.1)	13.7 (2.2)	11.9 (2.7)	19 (4.3)	50.1 (11.4)	26.9 (6.1)	101.1 (22.9)	41.0 (9.3)	158.0 (35.9)	54.0 (12.3)	319.7 (72.6)	170.0 (38.6)
Max. flow	Flow increase & connected	9.2 (2.1)	13.3 (3.0)	17.6 (4.0)	26.9 (6.1)	30.8 (7.0)	50.2 (11.4)	127.6 (29.0)	81.0 (18.4)	245.0 (55.6)	118.0 (18.4)	374.7 (85.1)	144.0 (32.7)	759.5 (172.5)	415.0 (94.2)
	Flow decrease & connected	8.1 (1.9)	12.5 (2.8)	16.3 (3.7)	25.1 (5.7)	28.6 (6.5)	47.1 (10.7)	122.0 (27.7)	76.2 (17.3)	234.7 (53.3)	111.0 (25.2)	359.7 (81.7)	134.7 (30.6)	729.6 (165.7)	400.6 (90.8)



Note : The flow rate suffixed with "Z" must be installed with 6-inch blades; The flow unit in the above table is GPM (m/h).

## Electrical Wiring

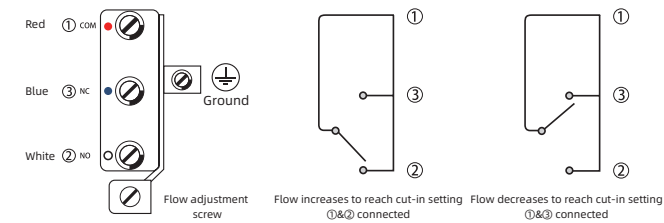

## Dimension (mm)

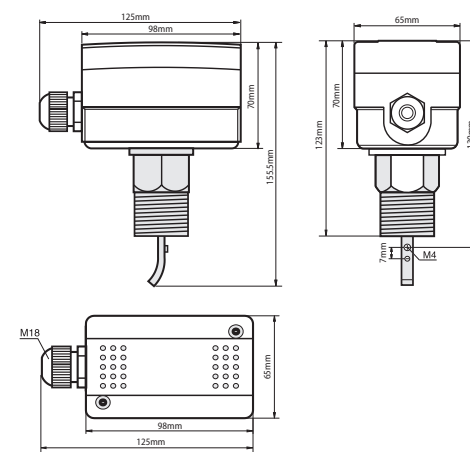

## Paddle

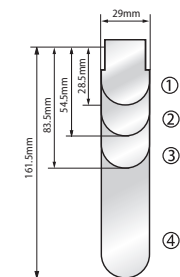

Install paddle	
Pipe size	No.
1"	1
1 1/4"	1
1 1/2"	1
2"	1,2
2 1/2"	1,2
3"	1,2,3
4"	1,2,3
4"Z	1,2,3,4
5"	1,2,3
5"Z	1,2,3,4
6"	1,2,3
6"Z	1,2,3,4
8"	1,2,3
8"Z	1,2,3,4

## Ordering Guide

Model	Connection	Product number
KWFS-1	1/2"-14NPT	02120000101600
KWFS-2	3/4"-14NPT	02120000111600
KWFS-3	1"-11 1/2NPT	02120000121600

# KWFS(S) Liquid Flow Switch



## Description

KWFS ( S ) series liquid flow switch are suitable for piping in industrial plants: heating and air conditioning, refrigeration systems and heat pumps; flow control of water and general liquid media.

## Features

- Flow control of water and common media
- New SPDT micro switch to ensure reliable switching function
- 15 (8A) 250VAC rated output value
- IP65
- Adjustable set value
- Stainless steel paddle
- 304 stainless steel material
- Maximum fluid temperature 120
- Maximum working pressure 13.5Ba

## Application

Applications for controlling and monitoring liquid flow in boilers, pumps, etc. of heating, cooling and air conditioning equipment.

## Technical Data

Operation type	On/Off, Single Stage, SPDT
Output	SPDT ,15(8A) 24/250VAC
Flow	See flow chart
Flow setting adjustment	Internal thread screw
Sensing element	Paddle
Media	Hot, cold, well, pool and sea water, brine or glycol
Materials of parts in contact with fluid	304 Stainless steel
Paddle material	Stainless steel
Liquid temperature	-20 ... 120
Operating temperature	-40 ... 85
Operating humidity	10 ... 90%RH ,no condensation
Cable interface	M18
Housing material	ABS+PC
Protection class	IP65
Color	white
Weight	1.0Kg

## Model

Model	Connection
KWFS(S)-1	1/2"-14 NPT
KWFS(S)-2	3/4"-14 NPT
KWFS(S)-3	1" -1 1/2"NPT

## Liquid Flow Rate Table

Line Pipe Size(in.)	1	1-1/4	1-1/2	2	2-1/2	3	4	4Z	5	5Z	6	6Z	8	8Z	
Min. flow	Flow increase & connected	4.2 (1.0)	5.8 (1.3)	7.5 (1.7)	13.7 (3.1)	17.6 (4.0)	27.5 (6.2)	64.7 (14.7)	35.2 (8.0)	12.5 (28.4)	57.01 (12.9)	90.0 (43.1)	74.0 (16.8)	374.7 (85.1)	204.7 (46.5)
	Flow decrease & connected	2.5 (0.6)	3.7 (0.8)	5.0 (1.1)	13.7 (2.2)	11.9 (2.7)	19 (4.3)	50.1 (11.4)	26.9 (6.1)	101.1 (22.9)	41.0 (9.3)	158.0 (35.9)	54.0 (12.3)	319.7 (72.6)	170.0 (38.6)
Max. flow	Flow increase & connected	9.2 (2.1)	13.3 (3.0)	17.6 (4.0)	26.9 (6.1)	30.8 (7.0)	50.2 (11.4)	127.6 (29.0)	81.0 (18.4)	245.0 (55.6)	118.0 (18.4)	374.7 (85.1)	144.0 (32.7)	759.5 (172.5)	415.0 (94.2)
	Flow decrease & connected	8.1 (1.9)	12.5 (2.8)	16.3 (3.7)	25.1 (5.7)	28.6 (6.5)	471 (10.7)	122.0 (27.7)	76.2 (17.3)	234.7 (53.3)	111.0 (25.2)	359.7 (81.7)	134.7 (30.6)	729.6 (165.7)	400.6 (90.8)



Note :  
The flow rate suffixed with "Z" must be installed with 6-inch blades; The flow unit in the

## Electrical Wiring

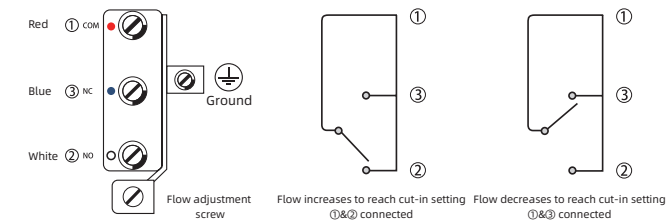

## Dimension (mm)

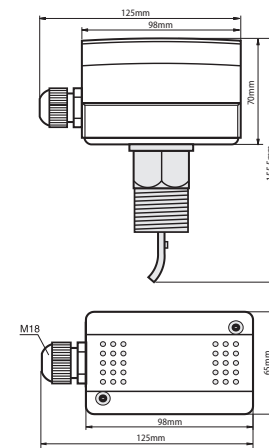

## Paddle

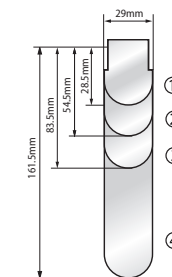

Install paddle	
Pipe size	No.
1"	1
1 1/4"	1
1 1/2"	1
2"	1,2
2 1/2"	1,2
3"	1,2,3
4"	1,2,3
4"Z	1,2,3,4
5"	1,2,3
5"Z	1,2,3,4
6"	1,2,3
6"Z	1,2,3,4
8"	1,2,3
8"Z	1,2,3,4

## Ordering Guide

Model	Connection	Product number
KWFS(S)-1	1/2"-14NPT	02370000101700
KWFS(S)-2	3/4"-14NPT	02370000111700
KWFS(S)-3	1"-11 1/2NPT	02370000121700



### Description

JWFS liquid flow switch are suitable for piping in industrial plants: heating and air conditioning, refrigeration systems and heat pumps; flow control of water and general liquid media.

### Features

- Flow control of water and common media
- New SPDT micro switch to ensure reliable switching function
- 15 (8A) 250VAC rated output value
- IP65
- Adjustable set value
- Stainless steel paddle
- Brass material
- Maximum fluid temperature 120
- Maximum working pressure 13.5Ba

### Application

Applications for controlling and monitoring liquid flow in boilers, pumps, etc. of heating, cooling and air conditioning equipment.

### Technical Data

Model	JWFS
Operation type	On/Off, Single Stage, SPDT
Output	单刀双掷 15(8A)24/250VAC
Flow	See flow chart
Flow setting adjustment	Internal thread screw
Sensing element	Paddle
Media	Hot, cold, well, pool and sea water, brine or glycol
Materials of parts in contact with fluid	Brass
Paddle material	Stainless steel
Liquid temperature	-20°C ... 120°C
Operating temperature	-40°C ... 85°C
Operating humidity	10 ... 90%RH, no condensation
Cable interface	M18 Fitting
Protection class	IP65
Color	Grey
Weight	1.3Kg

### Model

Model	Connection
JWFS-1	1/2"-14 NPT
JWFS-2	3/4"-14 NPT
JWFS-3	1-11 NPT12

### Liquid Flow Rate Table

		GPM(m <sup>3</sup> /hr) Required to Actuate Switch									
Pipe Size(in.)		1	1-1/4 <sup>1</sup>	1-1/2 <sup>1</sup>	2	2-1/2 <sup>2</sup>	3	4 <sup>3</sup>	5 <sup>3</sup>	6 <sup>3</sup>	8 <sup>3</sup>
Min adjustment	Flow increase (R to Y close)	4.2 (0.95)	5.8 (1.32)	7.50 (1.70)	13.7 (3.11)	18.0 (4.09)	27.5 (6.24)	65.0 (14.8)	125 (28.4)	190 (43.2)	375 (85.2)
	Flow decrease (R to B close)	2.20 (0.57)	3.70 (0.84)	5.00 (0.84)	9.50 (2.16)	12.5 (2.16)	19.0 (4.32)	50.0 (11.4)	101 (22.9)	158 (35.9)	320 (72.7)
Max adjustment	Flow increase (R to Y close)	8.80 (2.00)	13.3 (3.02)	19.2 (4.36)	29.0 (6.59)	34.5 (7.84)	53.0 (12.0)	128 (29.1)	245 (55.6)	375 (85.2)	760 (173)
	Flow decrease (R to B close)	8.50 (1.93)	12.5 (2.84)	18.0 (4.01)	27.0 (6.13)	32.0 (7.27)	50.01 (11.4)	122 (27.7)	235 (53.4)	360 (81.8)	730 (166)

### Electrical Wiring

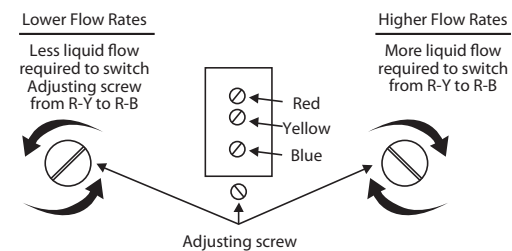

### Dimension (mm)

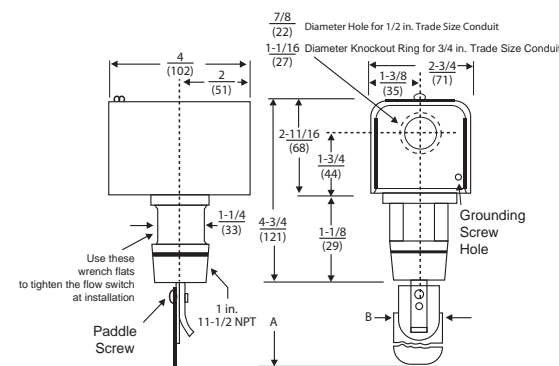

### Paddle

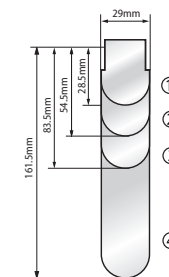

Install paddle	
Pipe size	No.
1"	1
1 1/4"	1
1 1/2"	1
2"	1,2
2 1/2"	1,2
3"	1,2,3
4"	1,2,3
4"Z	1,2,3,4
5"	1,2,3
5"Z	1,2,3,4
6"	1,2,3
6"Z	1,2,3,4
8"	1,2,3
8"Z	1,2,3,4

### Ordering Guide

Model	Connection	Product number
JWFS-1	1/2"-14NPT	02140000100000
JWFS-2	3/4"-14NPT	02140000110000
JWFS-3	1"-11 1/2NPT	02140000120000





## Description

- LQY series liquid flow switch is used to monitor flow changes
- The new SPDT micro switch ensures the reliability of the switching function
- The maximum temperature of the medium is 120 ° C
- Liquid pressure up to 1Mpa
- 3 stainless steel paddles, suitable for pipe diameter 25 - 75mm
- 6 additional paddles for 100 - 150mm pipe
- Protection class IP54
- Various connections available on request
- Maximum working pressure 13.5Bar
- Power supply AC250V 10A
- CE certification

## Contact Function

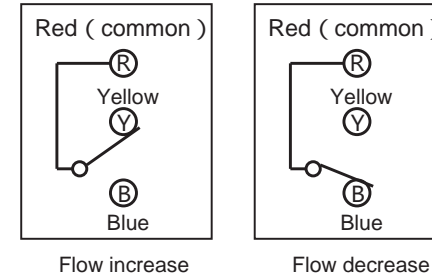

## Paddle

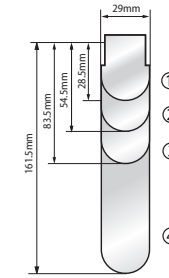

Install Paddle	
Pipe size	No.
1"	1
1 1/4"	1
1 1/2"	1
2"	1,2
2 1/2"	1,2
3"	1,2,3
4"	1,2,3
4"Z	1,2,3,4
5"	1,2,3
5"Z	1,2,3,4
6"	1,2,3
6"Z	1,2,3,4
8"	1,2,3
8"Z	1,2,3,4

## Dimension (mm)

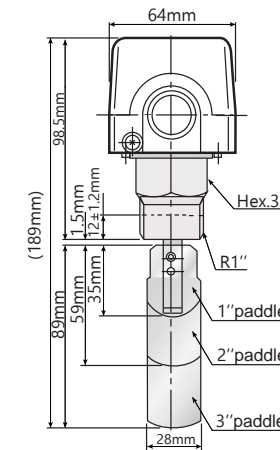
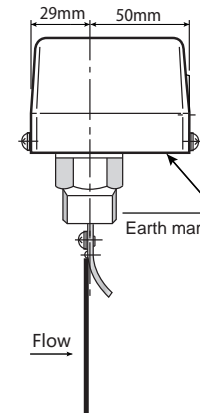

## Structure

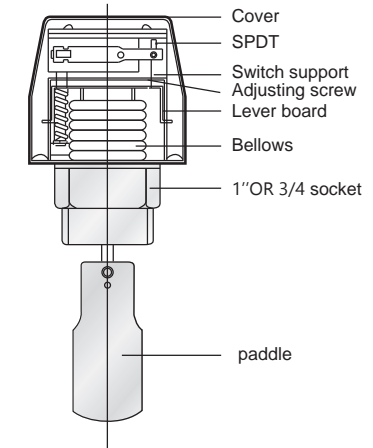

## Ordering Guide

Model	Connection	Product number
LQY 50P-1	1/2"-14NPT	02130000100000
LQY 50P-2	3/4"-14NPT	02130000110000
LQY 50P-3	1"-11 1/2NPT	02130000120000

## Liquid Flow Rate Table

pipe size(in.)		1	1-1/4	1-1/2	2	2-1/2	3	4	5	6	8
Min flow	Flow Increase R to Y	1.0	1.3	1.7	3.1	4.1	6.2	8.4	12.9	16.8	46.6
	Flow decrease R to B	0.6	0.1	1.1	2.2	2.8	4.3	6.1	9.3	12.3	38.6
Max flow	Flow increase R to Y close	2.0	3.0	4.4	6.6	7.8	12.0	18.4	26.8	32.7	94.2
	Flow decrease R to B close	1.9	2.8	4.1	6.1	7.3	11.4	17.3	25.2	30.7	90.8

## Model

Model	Connection	Note
LQY50P	1"-11 1/2NPT	Plastic case
LQY50P-1	1"-11 1/2NPT	
LQY50P-2	1/2"-14 NPT	

## Installation

- The direction of the arrow on the shell should be consistent with the flow direction in the pipeline;
- The water flow switch should be installed in a horizontal pipeline and must be installed vertically. If it needs to be installed on a vertical pipeline, the liquid flow should flow from bottom to top, and it is never allowed to be installed on a vertical pipeline that flows from top to bottom; the flow switch must be absolutely Reverse flow is not allowed to prevent the blades from breaking in reverse.



## Description

KFS1 series flow switch adopts a new structural design to avoid contact between electrical parts and metal parts with large temperature fluctuations, and to avoid corrosion caused by condensed water in electrical parts. The use of high sensitivity micro switches ensures good repeatability of the product; The ABS+PC composite shell enhances the protection level of the product and improves the service life of the product; the product covers a variety of models to adapt to different application scenarios and measurement media, and is widely used in flow protection on HVAC automatic control and industrial fluid control.

## Features

- HVAC system
- Industrial Automation System
- Air Compression & Industrial
- Refrigeration

## Dimension (mm)

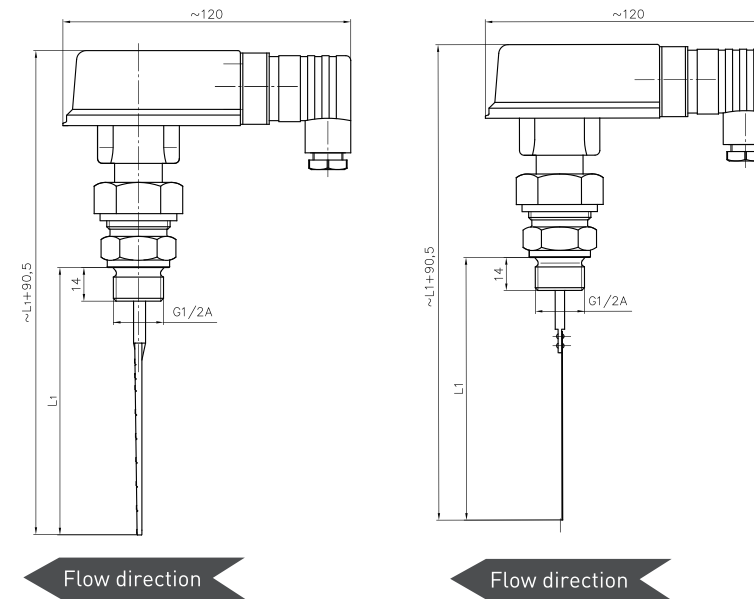

## Ordering Guide

Model	T joint size	Paddle Material	Wiring	Product number
KFS-1SO	G3/4"	Stainlee steel	Normal connection	02410000131710
KFS-1SH			Regular Hirschman connection	02410000131711
KFS-1SH-LED			Hessmann+Led light connector	02410000131712
KFS-1SH-4pin			4-pin plug connector	02410000131713
KFS-1PO		Plastic	Normal connection	02410000131810
KFS-1PH			Regular Hirschman connection	02410000131811
KFS-1PH-LED			Hessmann+Led light connector	02410000131812
KFS-1PH-4pin			4-pin plug connector	02410000131813

## Technical Data

Model	KFS1
Max voltage	250 Vac, no status light 24 Vdc±10%, status light
Max current	3A
Operating temperature	-20 ... +90°C
Withstand voltage	PN 25/25 bar
Storage temperature	-20 ... +70°C
Electrical connections	Regular outlet, Cable length 1.5m DIN EN 175301-803-A plug connector DIN EN 175301-803-A plug connector(LED status indicator) 4- Pin M12*1 aviation plug connector
Protection class	IP65
Average pressure loss	0.01 bar at Q.max
Material	Body: Nickel-plated brass Paddle: Stainless steel Seal: NBR Housing: PC+ABS
Media	Air or liquid

# KFS2 Series Flow Switch



## Description

KFS2 liquid flow switch is made of brass or stainless steel. It has the characteristics of small size, unique design, excellent performance, high cost performance, and environmental protection. Compared with traditional flow switches, it has higher performance. KFS2 adopts plug-in installation, mechanical and magnetic switches.

## Features

- Small pressure loss
- Good repeatability
- Dirty resistant
- Sealed separation of electrical and hydraulic
- Components without bellows
- Preservative

## Application

It is mainly suitable for industrial automation/mechanical equipment/pneumatic industry/refrigeration and air conditioning; it can also work normally in sewage discharge systems due to the sealed separation of its electrical and hydraulic components.

## Technical Data

Max power supply	250VAC ( no status light) 24VDC ± 10% (status light)
Max current	3A
connection method	DI 43650A c onnector/direct wiring (optional)
Output	SPST, one or two outputs optional, status light optional
Withstand voltage	25bar( optional )
Average pressure loss	0.01bar at maximum pressure
Operating temperature	-10~85
Protection class	IP65
Material	Valve body: nickel-plated brass; paddle: stainless steel; seal: NBR; housing: ABS+PC
Media	Water, oil and other non-corrosive gases

## Dimension (with T-fitting) (mm)

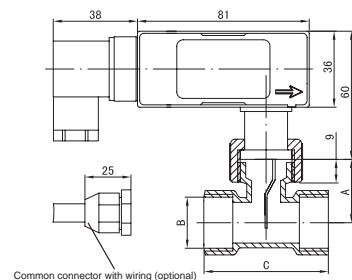

KFS2..BA with female thread T-fitting

Model	A	B	C
KFS2020BA	28	3/4"	58
KFS2025BA	34	1"	58
KFS2032BA	34	1 1/4"	72
KFS2040BA	34	1 1/2"	72
KFS2050BA	46	2"	72

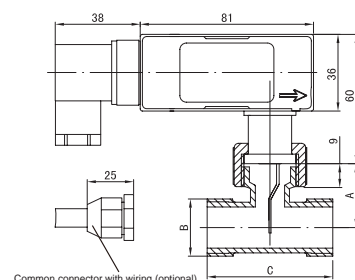

KFS2..BC with male tee

Model	A	B	C
KFS2020BC	28	3/4"	58
KFS2025BC	34	1"	58
KFS2032BC	34	1 1/4"	68

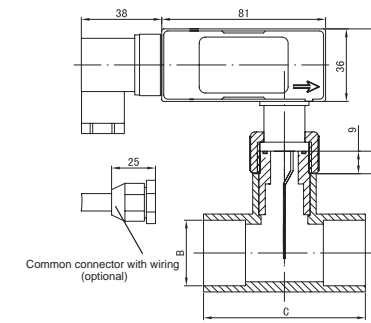

KFS2..BA with female thread T-fitting

Model	A	B	C
KFS2025BH	34.5	Ø25	68
KFS2032BH	38.5	Ø32	80
KFS2040BH	42	Ø40	90
KFS2050BH	48	Ø50	98.5
KFS2063BH	55	Ø63	110

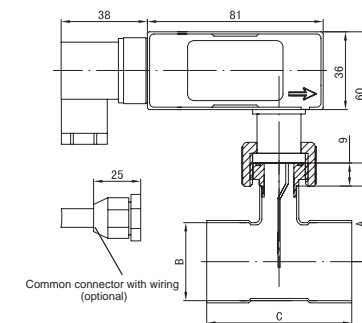

KFS2..BC with male thread T-fitting

Model	A	B	C
KFS2022BG	25	Ø22.3	55
KFS2025BG	27.5	Ø25.5	53
KFS2028BG	28.5	Ø28.8	56.7
KFS2032BG	32.8	Ø32.2	63.7
KFS2035BG	34.4	Ø35.1	66
KFS2042BG	35.4	Ø42.2	81.3

## Dimension (No T-fitting) (mm)

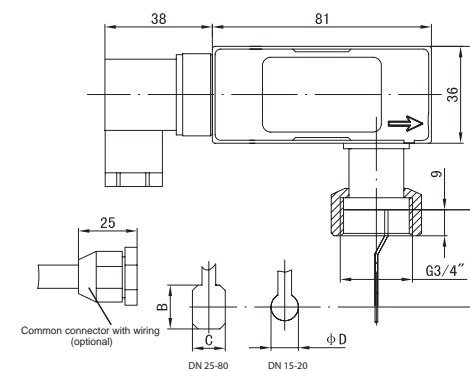

Model	A	B	C	D
KFS2020BD/F(20)	20	--	--	10
KFS2020BD/F(23)	24	--	--	10
KFS2020BD/F(24)	24	13.5	12	--
KFS2020BD/F(25)	26	16	12	--
KFS2020BD/F(26)	28	--	--	10
KFS2020BD/F(27)	28	13.5	12	--
KFS2020BD/F(28)	28	19	12	--
KFS2020BD/F(29)	30	16	12	--
KFS2020BD/F(30)	30	22	16	--
KFS2020BD/F(31)	32	--	--	10
KFS2020BD/F(32)	32	19	12	--
KFS2020BD/F(33)	34	13.5	12	--
KFS2020BD/F(34)	34	16	12	--
KFS2020BD/F(35)	34	22	16	--
KFS2020BD/F(36)	36	13.5	12	--
KFS2020BD/F(37)	36	19	12	--
KFS2020BD/F(38)	38	16	12	--
KFS2020BD/F(39)	38	22	16	--
KFS2020BD/F(40)	40	19	12	--
KFS2020BD/F(42)	42	22	16	--

Note: ( ) indicates the length of the paddle.

## Optional Connector

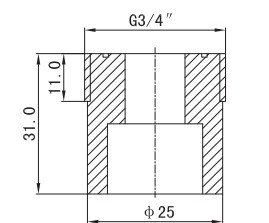

PVC external thread adapter

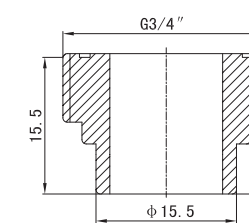

Solder Brass Connectors with copper T-fitting

Remark: "-A": Solder brass connector  
"-B": PVC external thread adapter

# KFS2 Series Flow Switch

## Optional T-fitting and Connectors

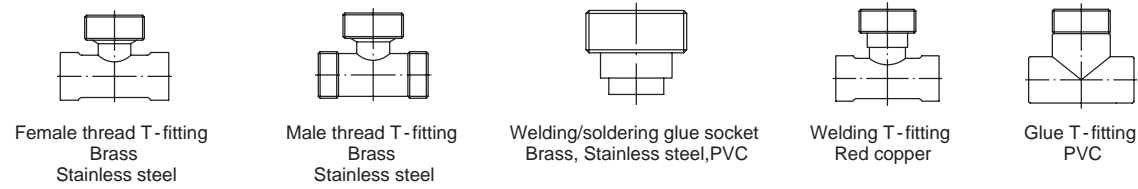

## Nomenclature

KFS2	008	B	A	1A	010	Specification
KFS2						KFSpaddle flow switch
	008					Nominal size : G1/4" ( T - fitting size )
	010					Nominal size : G3/8" ( T - fitting size )
	015					Nominal size : G1/2" ( T - fitting size )
	020					Nominal size : G3/4" ( T - fitting size )
	025					Nominal size : G1" ( T - fitting size )
	032					Nominal size : G1 - 3/4" ( T - fitting size )
	040					Nominal size : G1/2" ( T - fitting size )
	...					...
		A				Body material : H59 brass
		B				Body Material: Nickel Plated Brass
		P				Body material: engineering plastics
		S				Body material: stainless steel
			A			Connection method: internal thread T - fitting
			C			Connection method: external thread T - fitting
			D			Connection method: Welding/soldering glue connector
			E			Connection method: female thread insertion (no T - fitting), inlet
			F			Thread : G3/4" and G1"
			H			Connection method: threaded/plug - in (no T - fitting), imported
			G			Thread : G3/4"
				1A		Connection method: U - PVC plastic T - fitting
				2A		Connection method: Copper T - fitting
					1	Cable: DIN43650, the letter indicates the connection method, see the wiring
					...	...

## Before you order

1. Please indicate flow indication, measurement substance, nominal size and adjustable range in the order
2. For viscous liquids, please indicate the viscosity, temperature and measuring substance
3. For gaseous medium, please indicate the pressure (relative or absolute), temperature and measuring substance

## Ordering Guide

Model	T-fitting size	T-fitting material	Wiring	Product number	
KFS-2015BAO	G1/2"	Internal thread (brass)	Common qualifying	02400580141610	
KFS-2020BAO	G3/4"			02400580131610	
KFS-2025BAO	G1"			02400580461610	
KFS-2032BAO	G1 1/4"			02400580471610	
KFS-2040BAO	G1 1/2"			02400580481610	
KFS-2050BAO	G2"			02400580491610	
KFS-2015BCO	G1/2"	External thread (brass)		02400590141610	
KFS-2020BCO	G3/4"			02400590131610	
KFS-2025BCO	G1"			02400590461610	
KFS-2032BCO	G1 1/4"			02400590471610	
KFS-2040BCO	G1 1/2"			02400590481610	
KFS-2050BCO	G2"			02400590491610	
KFS-2025BHO	Φ25mm (PVC diameter)	PVC	02400600500010		
KFS-2032BHO	Φ32mm (PVC diameter)		02400600510010		
KFS-2040BHO	Φ40mm (PVC diameter)		02400600520010		
KFS-2050BHO	Φ50mm (PVC diameter)		02400600530010		
KFS-2022BGO	Φ22.3mm(copper diameter)	Brazed joints	02400610540010		
KFS-2025BGO	Φ25.5mm(copper diameter)		02400610550010		
KFS-2028BGO	Φ28.8mm(copper diameter)		02400610560010		
KFS-2032BGO	Φ32.2mm(copper diameter)		02400610570010		
KFS-2015BAH	G1"		Internal thread (brass)	02400580141611	
KFS-2020BAH	G1 1/4"			02400580131611	
KFS-2025BAH	G1 1/2"	02400580461611			
KFS-2032BAH	G2"	02400580471611			
KFS-2040BAH	G1/2"	02400580481611			
KFS-2050BAH	G3/4"	02400580491611			
KFS-2015BCH	G1"	External thread (brass)	02400590141611		
KFS-2020BCH	G1 1/4"		02400590131611		
KFS-2025BCH	G1 1/2"		02400590461611		
KFS-2032BCH	G2"		02400590471611		
KFS-2040BCH	G1/2"		02400590481611		
KFS-2050BCH	G3/4"		02400590491611		
KFS-2025BHH	Φ25mm (PVC diameter)	PVC	02400600500011		
KFS-2032BHH	Φ32mm (PVC diameter)		02400600510011		
KFS-2040BHH	Φ40mm (PVC diameter)		02400600520011		
KFS-2050BHH	Φ50mm (PVC diameter)		02400600530011		
KFS-2022BGH	Φ22.3mm(copper diameter)	Brazed joints	02400610540011		
KFS-2025BGH	Φ25.5mm(copper diameter)		02400610550011		
KFS-2028BGH	Φ28.8mm(copper diameter)		02400610560011		
KFS-2032BGH	Φ32.2mm(copper diameter)		02400610570011		
KFS-2015BAH-LED	G1 1/2"		Internal thread (brass)	Hessmann+ Led light connector	02400580141612
KFS-2020BAH-LED	G2"			02400580131612	

# KFS2 Series Flow Switch

# KMFS1 Series Flow Switch

## Ordering Guide

Model	T-fitting size	T-fitting material	Wiring	Product number
KFS-2025BAH-LED	G1/2"	Internal thread (brass)	Hessmann+ Led light connector	02400580461612
KFS-2032BAH-LED	G3/4"			02400580471612
KFS-2040BAH-LED	G1"			02400580481612
KFS-2050BAH-LED	G1 1/4"			02400580491612
KFS-2015BCH-LED	G1 1/2"	External thread (brass)		02400590141612
KFS-2020BCH-LED	G2"			02400590131612
KFS-2025BCH-LED	G1/2"			02400590461612
KFS-2032BCH-LED	G3/4"			02400590471612
KFS-2040BCH-LED	G1"	PVC		02400590481612
KFS-2050BCH-LED	G1 1/4"			02400590491612
KFS-2025BHH-LED	Φ25mm (PVC diameter)			02400600500012
KFS-2032BHH-LED	Φ32mm (PVC diameter)			02400600510012
KFS-2040BHH-LED	Φ40mm (PVC diameter)	Braze joints		02400600520012
KFS-2050BHH-LED	Φ50mm (PVC diameter)			02400600530012
KFS-2022BGH-LED	Φ22.3mm(copper diameter)			02400610540012
KFS-2025BGH-LED	Φ25.5mm(copper diameter)			02400610550012
KFS-2028BGH-LED	Φ28.8mm(copper diameter)	4-pin plug connector	02400610560012	
KFS-2032BGH-LED	Φ32.2mm(copper diameter)		02400610570012	
KFS-2015BA-4pin	G1/2"		02400580141613	
KFS-2020BA-4pin	G3/4"		02400580131613	
KFS-2025BA-4pin	G1"	Internal thread (brass)	02400580461613	
KFS-2032BA-4pin	G1 1/4"		02400580471613	
KFS-2040BA-4pin	G1 1/2"		02400580481613	
KFS-2050BA-4pin	G2"		02400580491613	
KFS-2015BC-4pin	G1/2"	External thread (brass)	02400590141613	
KFS-2020BC-4pin	G3/4"		02400590131613	
KFS-2025BC-4pin	G1"		02400590461613	
KFS-2032BC-4pin	G1 1/4"		02400590471613	
KFS-2040BC-4pin	G1 1/2"	PVC	02400590481613	
KFS-2050BC-4pin	G2"		02400590491613	
KFS-2025BH-4pin	Φ25mm (PVC diameter)		02400600500013	
KFS-2032BH-4pin	Φ32mm (PVC diameter)		02400600510013	
KFS-2040BH-4pin	Φ40mm (PVC diameter)	Braze joints	02400600520013	
KFS-2050BH-4pin	Φ50mm (PVC diameter)		02400600530013	
KFS-2022BG-4pin	Φ22.3mm(copper diameter)		02400610540013	
KFS-2025BG-4pin	Φ25.5mm(copper diameter)		02400610550013	
KFS-2028BG-4pin	Φ28.8mm(copper diameter)	4-pin plug connector	02400610560013	
KFS-2032BG-4pin	Φ32.2mm(copper diameter)		02400610570013	



## Description

KMFS1 electromagnetic flow switch is a target type paddle flow switch, mainly suitable for the refrigeration industry, indoor and commercial central air conditioners (water chillers)

## Features

- Use reed switch sensor, magnetic control, no power consumption
- High sensitivity and stable performance
- High product reliability, key components have passed UL certification
- Using a magnetic reed switch as the sensing element, the product has a long service life.
- The switch depends on the flow rate and has no relevant with temperature and pressure.
- Flexible application, can be selected according to actual application
- Different mounting connections and adjustable target lengths

## Technical Data

Model	KMFS1
Connection method	Normally open
operating temperature	-10~+ 70°C (not frozen)
Maximum power supply	25W
Max voltage	AC 220V+ 15% (0.1A MAX)
Max current	1A
Protection class	IP65
Humidity	90~95%,40°C,48H
Media temperature	MAX +100°C
Media	Water(no frozen)
Rating pressure	PN10 (0.1Mpa)
Mounted position	Vertical tube, downward flow or horizontal tube, horizontal flow

## Range

Nominal diameter	Threaded connection	Set value range		Max flow rate(L/min)
		Increase flow ON	Decrease flow OFF	
DN8	G1/4	2.7 ... 3.0	2.6 ... 2.9	15
DN10	G3/8	3.0 ... 3.8	2.8 ... 3.7	20
DN15	G1/2	3.8 ... 5.1	3.6 ... 4.9	30
DN15	G1/2 male	3.0 ... 3.8	2.8 ... 3.7	20
DN15	G3/4 male	3.0 ... 3.8	2.8 ... 3.7	20
DN20	G3/4	7.2 ... 9.0	6.9 ... 8.7	80
DN25	G1	13.0 ... 16.5	12.3 ... 15.9	130
DN32	G1 1/4	16.5 ... 21.0	16.0 ... 20.5	180
DN40	G1 1/2	27.0 ... 33.5	25.5 ... 32.5	300
DN50	G2	41.5 ... 53.5	40.6 ... 52.8	350

## Dimension (mm)

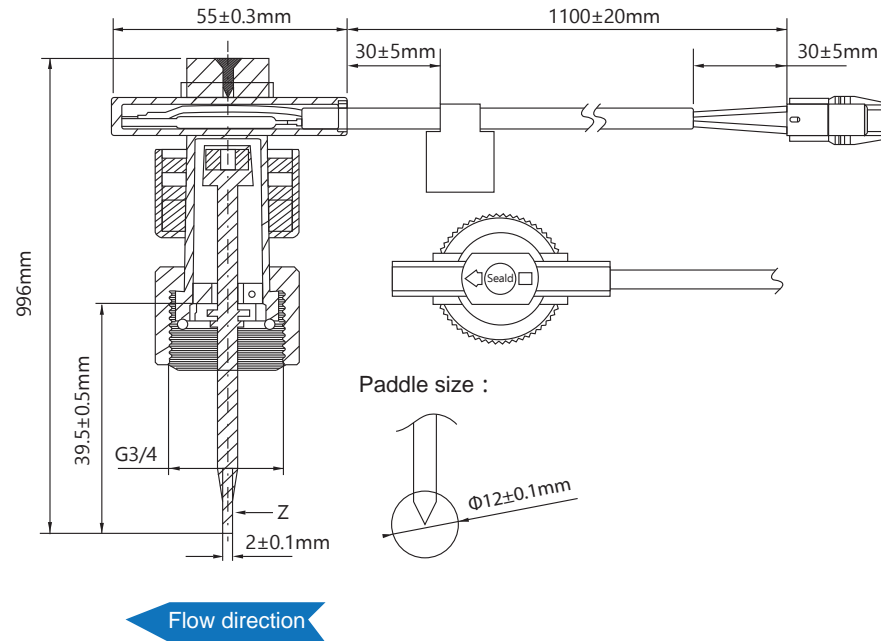

Threaded connection D1	L1	L2	H
G1/4	11	50	27
G3/8	11	50	27
G1/2	11	50	27
G1/2male	10	60	--
G3/4male	11	50	--
G3/4	15	50	32
G1	15	50	41
G1 1/4	15	50	48
G1 1/2	15	50	55
G2	22	64	70

## Ordering Guide

Model	T-fitting size	T-fitting material	Wiring	Product number
KMFS1-2015BAO	G1/2"	Internal thread (brass)	Common qualifying	02150580141610
KMFS1-2020BAO	G3/4"			02150580131610
KMFS1-2025BAO	G1"			02150580461610
KMFS1-2032BAO	G1 1/4"			02150580471610
KMFS1-2040BAO	G1 1/2"			02150580481610
KMFS1-2050BAO	G2"		02150580491610	
KMFS1-2015BAH	G1/2"		Hirschman joint	02150580141611
KMFS1-2020BAH	G3/4"			02150580131611
KMFS1-2025BAH	G1"			02150580461611
KMFS1-2032BAH	G1 1/4"			02150580471611
KMFS1-2040BAH	G1 1/2"	02150580481611		
KMFS1-2050BAH	G2"	02150580491611		
KMFS1-2015BAH-LED	G1/2"	Hessmann+ Led light connector	02150580141612	
KMFS1-2020BAH-LED	G3/4"		02150580131612	
KMFS1-2025BAH-LED	G1"		02150580461612	
KMFS1-2032BAH-LED	G1 1/4"		02150580471612	
KMFS1-2040BAH-LED	G1 1/2"		02150580481612	
KMFS1-2050BAH-LED	G2"	02150580491612		
KMFS1-2015BA-4Pin	G1/2"	4-pin plug connector	02150580141613	
KMFS1-2020BA-4Pin	G3/4"		02150580131613	
KMFS1-2025BA-4Pin	G1"		02150580461613	
KMFS1-2032BA-4Pin	G1 1/4"		02150580471613	
KMFS1-2040BA-4Pin	G1 1/2"		02150580481613	
KMFS1-2050BA-4Pin	G2"	02150580491613		
KMFS1-2015BCO	G1/2"	External thread (brass)	Common qualifying	02150590141610
KMFS1-2020BCO	G3/4"			02150590131610
KMFS1-2025BCO	G1"			02150590461610
KMFS1-2032BCO	G1 1/4"			02150590471610
KMFS1-2040BCO	G1 1/2"			02150590481610
KMFS1-2050BCO	G2"		02150590491610	
KMFS1-2015BCH	G1/2"		Hirschman joint	02150590141611
KMFS1-2020BCH	G3/4"			02150590131611
KMFS1-2025BCH	G1"			02150590461611
KMFS1-2032BCH	G1 1/4"			02150590471611
KMFS1-2040BCH	G1 1/2"	02150590481611		
KMFS1-2050BCH	G2"	02150590491611		
KMFS1-2015BCH-LED	G1/2"	Hessmann+ Led light connector	02150590141612	
KMFS1-2020BCH-LED	G3/4"		02150590131612	
KMFS1-2025BCH-LED	G1"		02150590461612	
KMFS1-2032BCH-LED	G1 1/4"		02150590471612	
KMFS1-2040BCH-LED	G1 1/2"		02150590481612	
KMFS1-2050BCH-LED	G2"	02150580141610		

# KMFS1 Series Flow Switch

# KMFS2 Series Flow Switch

## Ordering Guide

Model	T-fitting size	T-fitting material	Wiring	Product number		
KMFS1-2015BC-4Pin	G1/2"	External thread (brass)	4-pin plug connector	02150580131610		
KMFS1-2020BC-4Pin	G3/4"			02150580461610		
KMFS1-2025BC-4Pin	G1"			02150580471610		
KMFS1-2032BC-4Pin	G1 1/4"			02150580481610		
KMFS1-2040BC-4Pin	G1 1/2"			02150580491610		
KMFS1-2050BC-4Pin	G2"			02150580141611		
KMFS1-2025BHO	Φ25mm (PVC diameter)	PVC	Common qualifying	02150600500010		
KMFS1-2032BHO	Φ32mm (PVC diameter)			02150600510010		
KMFS1-2040BHO	Φ40mm (PVC diameter)			02150600520010		
KMFS1-2050BHO	Φ50mm (PVC diameter)			02150600530010		
KMFS1-2025BHH	Φ25mm (PVC diameter)			Hirschman joint	02150600500011	
KMFS1-2032BHH	Φ32mm (PVC diameter)				02150600510011	
KMFS1-2040BHH	Φ40mm (PVC diameter)		02150600520011			
KMFS1-2050BHH	Φ50mm (PVC diameter)		02150600530011	Hessmann+ Led light connector		
KMFS1-2025BHH-LED	Φ25mm (PVC diameter)		02150600500012			
KMFS1-2032BHH-LED	Φ32mm (PVC diameter)		02150600510012			
KMFS1-2040BHH-LED	Φ40mm (PVC diameter)		02150600520012			
KMFS1-2050BHH-LED	Φ50mm (PVC diameter)		02150600530012			
KMFS1-2025BH-4Pin	Φ25mm (PVC diameter)		4-pin plug connector		02150600500013	
KMFS1-2032BH-4Pin	Φ32mm (PVC diameter)			02150600510013		
KMFS1-2040BH-4Pin	Φ40mm (PVC diameter)			02150600520013		
KMFS1-2050BH-4Pin	Φ50mm (PVC diameter)			02150600530013		
KMFS1-2022BGO	Φ22.3mm(copper diameter)			Braze joints	Common qualifying	02150610540010
KMFS1-2025BGO	Φ25.5mm(copper diameter)					02150610550010
KMFS1-2028BGO	Φ28.8mm(copper diameter)	02150610560010				
KMFS1-2032BGO	Φ32.2mm(copper diameter)	02150610570010				
KMFS1-2022BGH	Φ22.3mm(copper diameter)	Hirschman joint	02150610540011			
KMFS1-2025BGH	Φ25.5mm(copper diameter)		02150610550011			
KMFS1-2028BGH	Φ28.8mm(copper diameter)		02150610560011			
KMFS1-2032BGH	Φ32.2mm(copper diameter)	02150610570011	Hessmann+ Led light connector			
KMFS1-2022BGH-LED	Φ22.3mm(copper diameter)	02150610540012				
KMFS1-2025BGH-LED	Φ25.5mm(copper diameter)	02150610550012				
KMFS1-2028BGH-LED	Φ28.8mm(copper diameter)	02150610560012				
KMFS1-2032BGH-LED	Φ32.2mm(copper diameter)	02150610570012				
KMFS1-2022BG-4Pin	Φ22.3mm(copper diameter)	4-pin plug connector			02150610540013	
KMFS1-2025BG-4Pin	Φ25.5mm(copper diameter)		02150610550013			
KMFS1-2028BG-4Pin	Φ28.8mm(copper diameter)		02150610560013			
KMFS1-2032BG-4Pin	Φ32.2mm(copper diameter)		02150610570013			



## Description

KMFS2 electromagnetic flow switch is a target type paddle flow switch, mainly suitable for the refrigeration industry, indoor and commercial central air conditioners (water chillers)

## Features

- Use reed switch sensor, magnetic control, no power consumption
- High sensitivity and stable performance
- High product reliability, key components have passed UL certification
- Using a magnetic reed switch as the sensing element, the product has a long service life.
- The switch depends on the flow rate and has nothing to do with temperature and pressure.
- Flexible application, can be selected according to actual application
- Different mounting connections and adjustable target lengths

## Technical Data

Model	KMFS2
Connection method	Normally open
operating temperature	-10~+70 (not frozen)
Maximum power supply	25W
Max voltage	AC 220V+ 15% (0.1A MAX)
Max current	1A
Protection class	IP 65
Humidity	90-95%,40 ,48H
Media temperature	Max+100
Media	Water(no frozen)
Rating pressure	PN10 (0.1Mpa)
Mounted position	Tee and Solder Sockets

## Range

Nominal diameter	Set value range		Max flow rate(L/min)
	Increase flow ON	Decrease flow OFF	
DN25	1 ... 1.2	0.9 ... 1	10
DN32	1.7 ... 2	1.5 ... 1.7	20
DN40	2 ... 3.3	1.8 ... 3	34
DN50	2.6 ... 4.8	2.4 ... 4.6	55
DN65	4.5 ... 8.8	4.2 ... 8.5	50
DN80	5.1 ... 13.8	4.7 ... 11.3	80
DN100	6.2 ... 18.8	5.9 ... 16.3	110
DN150	15.7 ... 27	14.3 ... 25	150
DN200	30 ... 45	29 ... 43.5	230

# KMFS2 Series Flow Switch

## Dimension (mm)

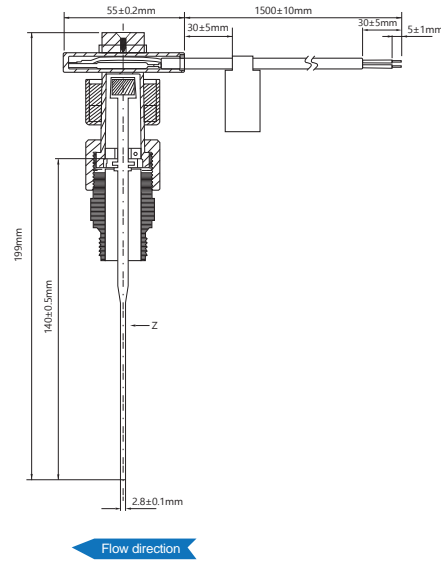

## Technical Data

Pressure	PN10
Temperature	
Media temperature	-25~100°C
Operating temperature	-25~70°C
Electrical data	
Electrical connections	1.5mPVC Sheathed cable
Current	Max.1A
Voltage	Max.230VAC, 48VDC
Max power	Max, 26VA, 20W
Protection class	IP65
Protection class	Class II

## Ordering Guide

Model	T-fitting size	T-fitting material	wiring	Product number
KMFS2-SO	G3/4"	Stainless steel	Normal connection	02160000131710
KMFS2-SH			Hirschman connection	02160000131711
KMFS2-SH-LED			Hessmann+Led light connector	02160000131712
KMFS2-S-4Pin			4-pin plug connector	02160000131713
KMFS2-PO		Plastic	Normal connection	02160000131810
KMFS2-PH			Hirschman connection	02160000131811
KMFS2-PH-LED			Hessmann+Led light connector	02160000131812
KMFS2-P-4Pin			4-pin plug connector	02160000131813

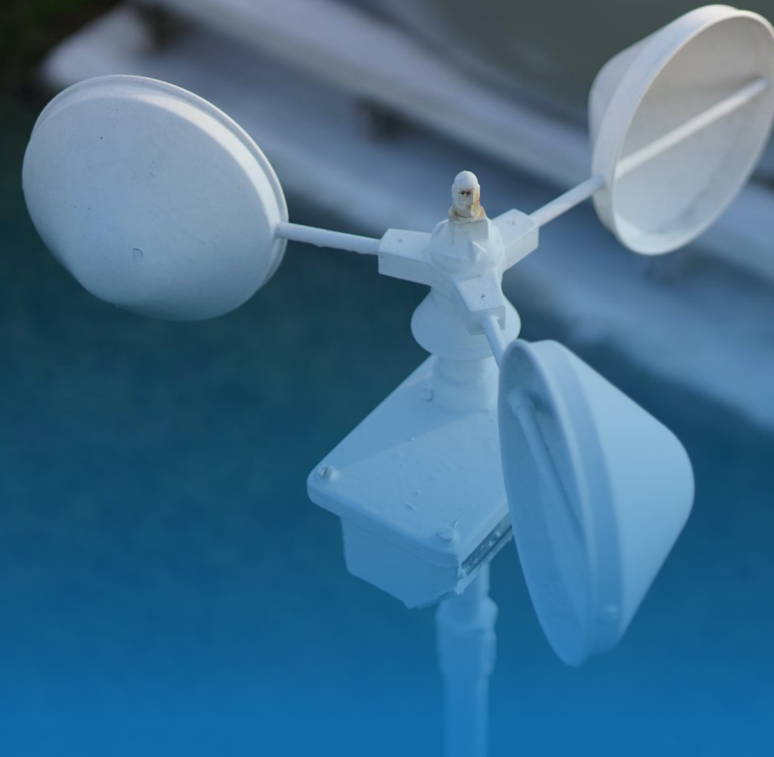

## Air Quality Sensors for Various Applications

Keram Controls air quality sensors cover a variety of air quality measurement applications, At the same time, the ventilation can be optimized and controlled on demand, so as to achieve energy saving and emission reduction. The product has high precision, multi-group parameter combination models, and various installation types.

**KeramControls®**





### Description

KAQ CO2 wall mounted transmitter for detection of CO2 in various room and oce spaces. For direct connection to a DDC or a monitoring system, using 4-20mA, 0-10V, Rs-485 outputs.

KAQ CO2 adopts single light source infrared measurement technology, which has high anti-pollution ability, long service life and high stability.

### Application

- HVAC system
- Energy-saving ventilation control
- Building automation

### Features

- Shell connected by hinge
- More convenient wiring and setting
- M16、 M20 double cable connector
- Meet the tribute to the installation of 12mm cable
- Smooth and at surface
- Prevent the pollution of the shell surface in harsh environment
- CO2 automatic calibration
- Long-term stability
- Temperature compensation

### Technical Data

Model	KAQ CO2
Power supply	16-30V DC (2 wire 4-20mA) 16-30V AC or V DC ( 0-10V/RS 485 )
Output	4-20mA / 0-10V/ Rs 485
Operating temperature	-10 ... +50°C
Operating humidity	0-95% non-condensing
Storage temperature	-30 ... +70°C
Response time	30s
Data Refresh Frequency	1s
Measuring range	0-10000 ppm
Accuracy	±50 ppm+5% measurements
Cable gland	M16*1.5 and M20*1.5

### Dimension (mm)

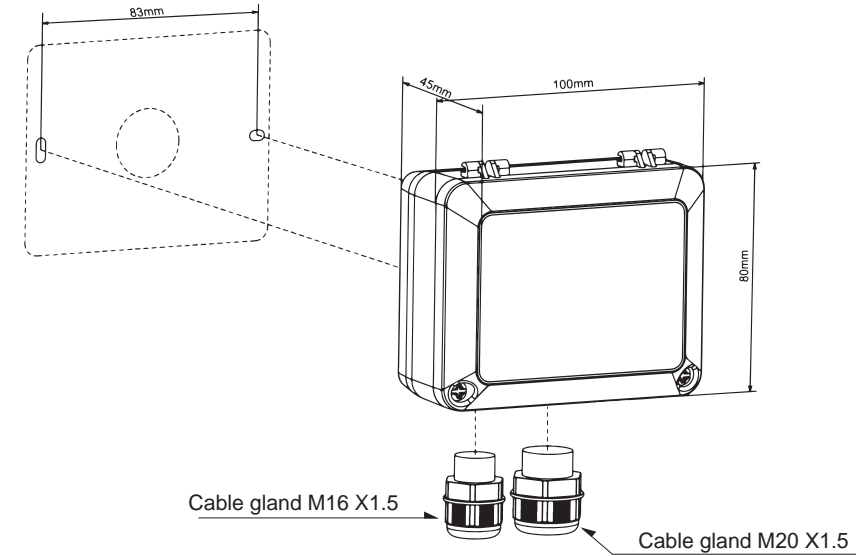

### Ordering Guide

Model	Output	Measuring range	Product number
KAQ CO2-E-2K	4-20mA (2 wire)	0-2000 ppm	0545000000114
KAQ CO2-E-5K		0-5000 ppm	0545000000115
KAQ CO2-E-10K		0-10000 ppm	0545000000116
KAQ CO2-G-2K	0-10V	0-2000 ppm	0545000000314
KAQ CO2-G-5K		0-5000 ppm	0545000000315
KAQ CO2-G-10K		0-10000 ppm	0545000000316
KAQ CO2-H-2K	RS485	0-2000 ppm	0545000000414
KAQ CO2-H-5K		0-5000 ppm	0545000000415
KAQ CO2-H-10K		0-10000 ppm	0545000000416



### Application

- HVAC System
- Greenhouse
- Food transportation
- Refrigeration
- Clean room environment

### Description

KTHP100 Series Temperature Humidity & Differential Pressure Transmitters are used to measure relative humidity, temperature and differential pressure in various application areas, as well as monitor building energy management systems. KTHP100 series temperature, humidity & differential pressure transmitters are easy to install, have high precision, stable and reliable operation, and are ideal for various harsh environments.

### Features

- Shell connected by hinge
- More convenient wiring and setting
- M16、M20 double cable connector
- Meet the tribute to the installation of 12mm cable
- Smooth and at surface
- Prevent the pollution of the shell surface in harsh environment
- IP65/NEMA4

### Technical Data

Model	KTHP100
Power supply	16-30V DC (2 wire 4-20mA)/16-30V AC or VDC (0-5V/0-10V/RS 485)
Output	4-20mA / 0-5V / 0-10V/ RS 485
Operating temperature	-35°C ... +70°C
Storage temperature	-40°C ... +80°C
Operating humidity	0~100%RH
Temperature range	DIP
Display	Backlight LCD
Max wind speed/flow rate	30m/s
Electromagnetic compatibility	EN61326-1 (industrial environment)
Housing material	PC+ABS( UL-V0 )
Protection class	IP65/NEMA 4
Cable gland	M16*1.5/M20*1.5
<b>Measuring Performance - Temperature</b>	
Measuring range	-35 ... +80°C
Accuracy	±0.3°C(20-60°C)
Temperature Coefficient	±0.01°C/°C
<b>Measuring Performance - Humidity</b>	
Measuring range	0 ... 100%RH
Accuracy	±2%(0-90%@25°C)/±3%(90-100%@25°C)
Humidity Coefficient	±1%RH/year
<b>Measuring Performance - differential pressure</b>	
Measuring unit	Pa, mmH <sub>2</sub> O, inWG, mmHG, kPa, mbar
Accuracy	< ±1%FS@-5 to +65°C
Response time	0.5s
Repeat stability	±0.01% at FS/year
Resolution	0.1 Pa; 0.1 mmH <sub>2</sub> O; 0.01mbar; 0.01mmHG

### Dimension (mm)

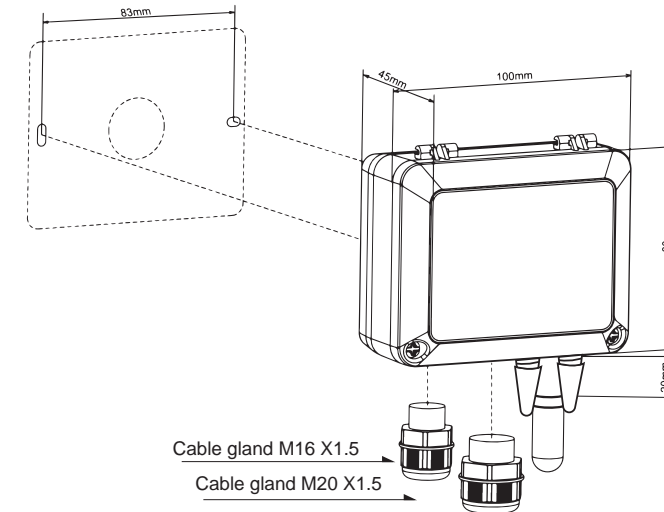

### Manual Zero-point Correction

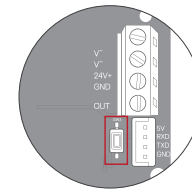

In normal operation zero point correction should be executed every 12 months. For executing zero point correction the power supply must be connected one hour before.

- Release both connection tubes from the pressure terminals + and -
- Press and hold the button for 3 seconds
- Reinstall the connection tubes

### Accessory (optional)

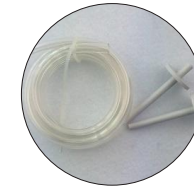

Pressure connection components 2m PVC hose and 2 ABS pressure fittings

### Note On Disposal



Most Keram Controls products may contain valuable materials which should be recycled rather than treated as domestic waste. Please pay attention to the relevant regulations of local disposal.

### Product Certification



CE  
The declaration of conformity of the products can be found on our website  
<https://www.keramcontrols.com>

# KTHP100 Diff pressure & temp and RH Transmitter

## Accessory - Pipe Tee

### Ordering Guide

■ Display × No display

Model	Pressure range	Output	Display	Filter	Product number		
KTHP100-2DEP	±1000Pa	4-20mA (2 wire)	■	PTFE	05460010010117		
KTHP100-2DES				Stainless steel	05460010010118		
KTHP100-2DGP		0-10V		×	PTFE	05460010010317	
KTHP100-2DGS					Stainless steel	05460010010318	
KTHP100-2DHP		RS485			■	PTFE	05460010010417
KTHP100-2DHS						Stainless steel	05460010010418
KTHP100-2EP		4-20mA (2 wire)	×			PTFE	05460010020117
KTHP100-2ES						Stainless steel	05460010020118
KTHP100-2GP		0-10V		■		PTFE	05460010020317
KTHP100-2GS						Stainless steel	05460010020318
KTHP100-2HP		RS485			×	PTFE	05460010020417
KTHP100-2HS						Stainless steel	05460010020418
KTHP100-3DEP	±2000Pa	4-20mA (2 wire)	■			PTFE	05460020010117
KTHP100-3DES						Stainless steel	05460020010118
KTHP100-3DGP		0-10V		×		PTFE	05460020010317
KTHP100-3DGS						Stainless steel	05460020010318
KTHP100-3DHP		RS485			■	PTFE	05460020010417
KTHP100-3DHS						Stainless steel	05460020010418
KTHP100-3EP		4-20mA (2 wire)	×			PTFE	05460020020117
KTHP100-3ES						Stainless steel	05460020020118
KTHP100-3GP		0-10V		■		PTFE	05460020020317
KTHP100-3GS						Stainless steel	05460020020318
KTHP100-3HP		RS485			×	PTFE	05460020020417
KTHP100-3HS						Stainless steel	05460020020418
KTHP100-4DEP	±10000Pa	4-20mA (2 wire)	■			PTFE	05460030010117
KTHP100-4DES						Stainless steel	05460030010118
KTHP100-4DGP		0-10V		×		PTFE	05460030010317
KTHP100-4DGS						Stainless steel	05460030010318
KTHP100-4DHP		RS485			■	PTFE	05460030010417
KTHP100-4DHS						Stainless steel	05460030010418
KTHP100-4EP		4-20mA (2 wire)	×			PTFE	05460030020117
KTHP100-4ES						Stainless steel	05460030020118
KTHP100-4GP		0-10V		■		PTFE	05460030020317
KTHP100-4GS						Stainless steel	05460030020318
KTHP100-4HP		RS485			×	PTFE	05460030020417
KTHP100-4HS						Stainless steel	05460030020418
KTHP100-1DEP	±100Pa	4-20mA (2 wire)	■			PTFE	05460640010117
KTHP100-1DES						Stainless steel	05460640010118
KTHP100-1DGP		0-10V		×		PTFE	05460640010317
KTHP100-1DGS						Stainless steel	05460640010318
KTHP100-1DHP		RS485			■	PTFE	05460640010417
KTHP100-1DHS						Stainless steel	05460640010418
KTHP100-1EP		4-20mA (2 wire)	×			PTFE	05460640020117
KTHP100-1ES						Stainless steel	05460640020118
KTHP100-1GP		0-10V		■		PTFE	05460640020317
KTHP100-1GS						Stainless steel	05460640020318
KTHP100-1HP		RS485			×	PTFE	05460640020417
KTHP100-1HS						Stainless steel	05460640020418

### Product Picture



### Ordering Guide

Model	Type	Material	Size	Product number		
SP-FC-15FB	Internal thread T fitting	Brass	DN15	0647058042016000		
SP-FC-15FS				0647058042017000		
SP-FC-20FB			DN20	0647058043016000		
SP-FC-20FS				0647058043017000		
SP-FC-25FB			DN25	0647058044016000		
SP-FC-25FS				0647058044017000		
SP-FC-32FB			DN32	0647058045016000		
SP-FC-32FS				0647058045017000		
SP-FC-40FB			DN40	0647058046016000		
SP-FC-40FS				0647058046017000		
SP-FC-15MB			External thread T fitting	Brass	DN15	0647059042016000
SP-FC-15MS						0647059042017000
SP-FC-20MB	DN20	0647059043016000				
SP-FC-20MS		0647059043017000				
SP-FC-25MB	DN25	0647059044016000				
SP-FC-25MS		0647059044017000				
SP-FC-32MB	DN32	0647059045016000				
SP-FC-32MS		0647059045017000				
SP-FC-40MB	DN40	0647059046016000				
SP-FC-40MS		0647059046017000				
SP-FC-25P	PVC-T fitting	PVC			Φ25mm	0647060047000000
SP-FC-32P					Φ32mm	0647060048000000
SP-FC-40P			Φ40mm	0647060049000000		
SP-FC-50P			Φ50mm	0647060050000000		
SP-FC-22W			Brazeed T-fitting	Brass	Φ22.3mm	0647061051000000
SP-FC-25W	Φ25.5mm	0647061052000000				
SP-FC-28W	Φ28.8mm	0647061053000000				
SP-FC-32W	Φ32.2mm	0647061054000000				

# Accessory - Humidity Sensor Filter

# Accessory - Humidity Sensor Flange

## Product Picture



SP-RH-Filter-01



SP-RH-Filter-02



SP-RH-Filter-03



SP-RH-Filter-04

## Ordering Guide

Model	Interface thread	Outer diameter	Material	Product number
SP-RH-Filter-01	M10*1.0	Φ12mm	Stainless steel	0648062055017000
SP-RH-Filter-02	M10*1.0		PTFE	0648062055019000
SP-RH-Filter-03	M10*1.0	Φ14.6mm	Plastic	0648062055020000
SP-RH-Filter-04	M12*1.0		Stainless steel	0648063056017000

## Product Picture



## Dimension(mm)

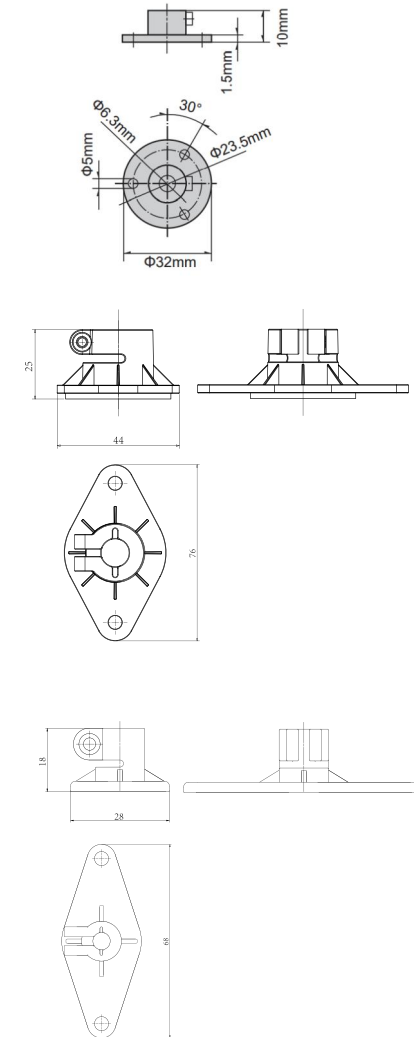

## Ordering Guide

Model	Output	Measuring range	Product number
SP-RH-Flange-01	Φ12mm	Plastic	0649000055020000
SP-RH-Flange-02	Φ6mm		0649000057020000
SP-RH-Flange-03	Φ6mm	Stainless steel	0649000057017000

# Accessory - Pressure nipples

## Product Picture



## Dimension(mm)

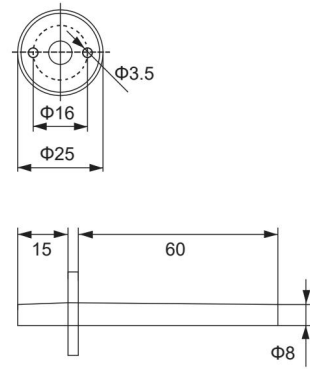

## Ordering Guide

Model	Components	Product number
SP-PC-01	2m PVC hose	065000000020000
	2*ABS Pressure taker	
	4*Fixing screws	

# Accessory - Immersion sleeve

## Product Picture



## Dimension(mm)

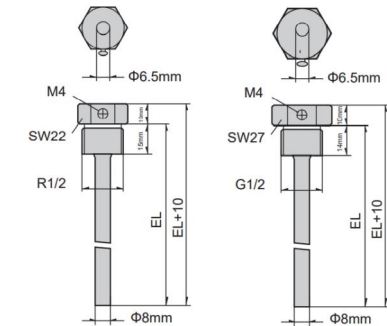

## Ordering Guide

Model	Pipe diameter	Length	Material	Product number
SP-T-Pockets-B-100-6	Φ6mm	100mm	Brass	0651065057016000
SP-T-Pockets-S-100-6			Stainless steel	0651065057017000
SP-T-Pockets-B-100-8	Φ8mm	100mm	Brass	0651065058016000
SP-T-Pockets-S-100-8			Stainless steel	0651065058017000
SP-T-Pockets-B-150-6	Φ6mm	150mm	Brass	0651066057016000
SP-T-Pockets-S-150-6			Stainless steel	0651066057017000
SP-T-Pockets-B-150-8	Φ8mm	150mm	Brass	0651066058016000
SP-T-Pockets-S-150-8			Stainless steel	0651066058017000
SP-T-Pockets-B-200-6	Φ6mm	200mm	Brass	0651067057016000
SP-T-Pockets-S-200-6			Stainless steel	0651067057017000
SP-T-Pockets-B-200-8	Φ8mm	200mm	Brass	0651067058016000
SP-T-Pockets-S-200-8			Stainless steel	0651067058017000
SP-T-Pockets-B-250-6	Φ6mm	250mm	Brass	0651068057016000
SP-T-Pockets-S-250-6			Stainless steel	0651068057017000
SP-T-Pockets-B-250-8	Φ8mm	250mm	Brass	0651068058016000
SP-T-Pockets-S-250-8			Stainless steel	0651068058017000
SP-T-Pockets-B-300-6	Φ6mm	300mm	Brass	0651069057016000
SP-T-Pockets-S-300-6			Stainless steel	0651069057017000
SP-T-Pockets-B-300-8	Φ8mm	300mm	Brass	0651069058016000
SP-T-Pockets-S-300-8			Stainless steel	0651069058017000

### Product Picture



### Dimension(mm)

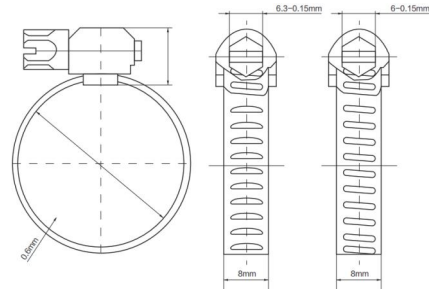

### Ordering Guide

Model	Pipe diameter	Material	Product number
SP-T-Clamp-S-250MM	Φ250~400mm	Stainless steel	0652000059017000
SP-T-Clamp-S-400MM	Φ400~600mm		0652000060017000
SP-T-Clamp-S-600MM	Φ600~800mm		0652000061017000
SP-T-Clamp-S-800MM	Φ800~1000mm		0652000062017000
SP-T-Clamp-S-1000MM	Φ1000~1600mm		0652000063017000

### ISO Certification



### Appearance Design Patent Certificate



## NTC10K B3950 Resistance Value (Ω)

TEMP (°C)	0	-1	-2	-3	-4	-5	-6	-7	-8	-9
-40	343.6326	367.7258	393.7107	421.7511	452.0267	484.7341	520.089	558.3278	599.71	644.5208
-30	179.2666	190.9144	203.4118	216.8273	231.2355	246.7177	263.3624	281.266	300.5339	321.2809
-20	97.8396	103.7512	110.0648	116.8107	124.0216	131.7332	139.9837	148.8151	158.2726	168.4053
-10	55.5953	58.7288	62.0616	65.6077	69.3823	73.4018	77.6837	82.2471	87.1124	92.302
0	32.7547	34.4817	36.3117	38.2516	40.3086	42.4906	44.8062	47.2643	49.8747	52.648
10	32.7547	31.1243	29.5847	28.1301	26.7556	25.4562	24.2274	23.065	21.965	20.9239
20	19.938	19.0041	18.1193	17.2807	16.4857	15.7317	15.0164	14.3376	13.6933	13.0816
30	8.0512	7.7154	7.3953	7.0903	6.7995	6.5221	6.2576	6.0051	5.7642	5.5342
40	5.3146	5.1049	4.9045	4.713	4.53	4.351	4.1878	4.0278	3.8748	3.7283
50	3.5882	3.454	3.3255	3.2025	3.0846	2.9717	2.8635	2.7597	2.6603	2.5649
60	2.4734	2.3856	2.3014	2.2206	2.1431	2.0686	1.997	1.9283	1.8623	1.7989
70	1.738	1.6794	1.6231	1.5689	1.5168	1.4667	1.4185	1.3722	1.3275	1.2845
80	1.2431	1.2033	1.1649	1.1279	1.0923	1.058	1.0249	0.993	0.9623	0.9326
90	0.904	0.8764	0.8498	0.8241	0.7994	0.7754	0.7523	0.73	0.7085	0.6877
100	0.6676	0.6482	0.6295	0.6113	0.5938	0.5769	0.5605	0.5447	0.5293	0.5145
110	0.5002	0.4863	0.4729	0.4599	0.4474	0.4352	0.4234	0.412	0.4009	0.3902
120	0.3799	0.3698	0.3601	0.3506	0.3415	0.3326	0.324	0.3157	0.3076	0.2998
130	0.2922	0.2848	0.2776	0.2707	0.264	0.2574	0.2511	0.2449	0.2389	0.2331
140	0.2274	0.222	0.2166	0.2114	0.2064	0.2015	0.1968	0.1922	0.1877	0.1833
150	0.1791	0.1749	0.1709	0.167	0.1632	0.1595	0.1559	0.1524	0.149	0.1457
160	0.1425	0.1394	0.1363	0.1333	0.1304	0.1276	0.1249	0.1222	0.1196	0.117
170	0.1146	0.1121	0.1098	0.1075	0.1053	0.1031	0.101	0.0989	0.0969	0.0949
180	0.093	0.0911	0.0893	0.0875	0.0858	0.0841	0.0824	0.0808	0.0792	0.0777
190	0.0762	0.0747	0.0733	0.0719	0.0705	0.0692	0.0679	0.0666	0.0654	0.0642
200	0.063	0.0618	0.0607	0.0596	0.0585	0.0574	0.0564	0.0554	0.0544	0.0534

## NTC10K B3435 Resistance Value (Ω)

TEMP (°C)	0	-1	-2	-3	-4	-5	-6	-7	-8	-9
-40	202.2693	214.2231	226.981	240.6035	255.1561	270.7097	287.3413	305.1344	324.1796	344.5753
-30	116.5089	122.8985	129.6879	136.9052	144.5807	152.7468	161.4387	170.6944	180.5546	191.0637
-20	69.6931	73.2523	77.0194	81.0082	85.2332	89.7101	94.4558	99.4883	104.8272	110.4932
-10	43.1172	45.1743	47.3439	49.633	52.049	54.5998	57.2939	60.1402	63.1485	66.3291
0	27.4936	28.7225	30.0145	31.3734	32.8029	34.3074	35.891	37.5587	39.3153	41.1663
10	27.4936	26.3245	25.2119	24.1527	23.1442	22.1835	21.2682	20.3959	19.5644	18.7714
20	18.0151	17.2935	16.6048	15.9475	15.3198	14.7203	14.1475	13.6003	13.0772	12.5771
30	12.0988	11.6413	11.2037	10.7848	10.3839	10	9.6324	9.2802	8.9428	8.6195
40	8.3096	8.0124	7.7275	7.4541	7.1919	6.9403	6.6987	6.4669	6.2442	6.0304
50	5.825	5.6276	5.438	5.2557	5.0804	4.9119	4.7498	4.5939	4.4439	4.2995
60	4.1605	4.0268	3.898	3.7739	3.6544	3.5393	3.4284	3.3215	3.2185	3.1191
70	3.0234	2.931	2.8419	2.7559	2.6729	2.5929	2.5156	2.441	2.369	2.2994
80	2.2322	2.1673	2.1046	2.044	1.9854	1.9288	1.874	1.8211	1.7699	1.7204
90	1.6725	1.6262	1.5813	1.5379	1.4959	1.4553	1.4159	1.3778	1.3408	1.3051
100	1.2704	1.2368	1.2043	1.1728	1.1422	1.1126	1.0839	1.056	1.029	1.0028
110	0.9774	0.9527	0.9288	0.9055	0.883	0.8611	0.8399	0.8193	0.7992	0.7798
120	0.7609	0.7425	0.7247	0.7074	0.6906	0.6742	0.6583	0.6429	0.6278	0.6132
130	0.599	0.5852	0.5718	0.5587	0.546	0.5336	0.5216	0.5098	0.4984	0.4873
140	0.4765	0.466	0.4558	0.4458	0.4361	0.4266	0.4174	0.4084	0.3997	0.3911
150	0.3828	0.3747	0.3669	0.3592	0.3517	0.3444	0.3372	0.3303	0.3235	0.3169
160	0.3104	0.3042	0.298	0.292	0.2862	0.2805	0.2749	0.2695	0.2642	0.259
170	0.254	0.249	0.2442	0.2395	0.2349	0.2304	0.226	0.2218	0.2176	0.2135
180	0.2095	0.2056	0.2018	0.198	0.1944	0.1908	0.1874	0.1839	0.1806	0.1774
190	0.1742	0.1711	0.168	0.165	0.1621	0.1593	0.1565	0.1538	0.1511	0.1485
200	0.1459	0.1434	0.141	0.1386	0.1362	0.1339	0.1317	0.1295	0.1273	0.1252
210	0.1231	0.1211	0.1191	0.1172	0.1153	0.1134	0.1116	0.1098	0.108	0.1063

Verification No. CL100001008

**VERIFICATION OF LVD COMPLIANCE**

Applicant: KreamControl Electrical Equipment Co., Ltd.  
 Address of Applicant: No. 2 Building, Jiangping West Road (Jiangping West Road), Jiangping Street, Jiangping District, Jiangsu Province, Jiangsu, China.  
 Manufacturer: KreamControl Electrical Equipment Co., Ltd.  
 Product Description: Temperature and humidity transmitter, Temperature transmitter  
 Model No.: K3950, K3435

Substantive number of the product has been added and notified to be conforming with:  
 Test Standard: EN 61010-1:2010  
 As Annex to the:  
 Test Report No.: CL100001008  
 Date of Issue: August 2020  
 Date of Expiry: August 2023

The manufacturer of CE Declaration has been granted to sign based on the results of the conformity assessment of the product being notified. CE is a symbol of the administrative process conducted with the approval of the competent authority in the Member State. The CE Declaration is a statement of the manufacturer's responsibility for the conformity of the product with the CE Declaration of Conformity and is not a statement of the manufacturer's responsibility for the conformity of the product with the CE Declaration of Conformity. The manufacturer is responsible for the conformity of the product with the CE Declaration of Conformity. The manufacturer is responsible for the conformity of the product with the CE Declaration of Conformity. The manufacturer is responsible for the conformity of the product with the CE Declaration of Conformity.

Approved by KreamControl  
 For an authorized signatory of the manufacturer  
 Signature: [Signature]  
 Name: [Name]  
 Title: [Title]

Approved by GTS  
 For an authorized signatory of the notified body  
 Signature: [Signature]  
 Name: [Name]  
 Title: [Title]

Verification No. CL100001009

**VERIFICATION OF LVD COMPLIANCE**

Applicant: KreamControl Electrical Equipment Co., Ltd.  
 Address of Applicant: No. 2 Building, Jiangping West Road (Jiangping West Road), Jiangping Street, Jiangping District, Jiangsu Province, Jiangsu, China.  
 Manufacturer: KreamControl Electrical Equipment Co., Ltd.  
 Product Description: Temperature and humidity transmitter, Temperature transmitter  
 Model No.: K3950, K3435

Substantive number of the product has been added and notified to be conforming with:  
 Test Standard: EN 61010-1:2010  
 As Annex to the:  
 Test Report No.: CL100001009  
 Date of Issue: August 2020  
 Date of Expiry: August 2023

The manufacturer of CE Declaration has been granted to sign based on the results of the conformity assessment of the product being notified. CE is a symbol of the administrative process conducted with the approval of the competent authority in the Member State. The CE Declaration is a statement of the manufacturer's responsibility for the conformity of the product with the CE Declaration of Conformity and is not a statement of the manufacturer's responsibility for the conformity of the product with the CE Declaration of Conformity. The manufacturer is responsible for the conformity of the product with the CE Declaration of Conformity. The manufacturer is responsible for the conformity of the product with the CE Declaration of Conformity. The manufacturer is responsible for the conformity of the product with the CE Declaration of Conformity.

Approved by KreamControl  
 For an authorized signatory of the manufacturer  
 Signature: [Signature]  
 Name: [Name]  
 Title: [Title]

Approved by GTS  
 For an authorized signatory of the notified body  
 Signature: [Signature]  
 Name: [Name]  
 Title: [Title]

Verification No. CL100001010

**VERIFICATION OF LVD COMPLIANCE**

Applicant: KreamControl Electrical Equipment Co., Ltd.  
 Address of Applicant: No. 2 Building, Jiangping West Road (Jiangping West Road), Jiangping Street, Jiangping District, Jiangsu Province, Jiangsu, China.  
 Manufacturer: KreamControl Electrical Equipment Co., Ltd.  
 Product Description: Temperature and humidity transmitter, Temperature transmitter  
 Model No.: K3950, K3435

Substantive number of the product has been added and notified to be conforming with:  
 Test Standard: EN 61010-1:2010  
 As Annex to the:  
 Test Report No.: CL100001010  
 Date of Issue: August 2020  
 Date of Expiry: August 2023

The manufacturer of CE Declaration has been granted to sign based on the results of the conformity assessment of the product being notified. CE is a symbol of the administrative process conducted with the approval of the competent authority in the Member State. The CE Declaration is a statement of the manufacturer's responsibility for the conformity of the product with the CE Declaration of Conformity and is not a statement of the manufacturer's responsibility for the conformity of the product with the CE Declaration of Conformity. The manufacturer is responsible for the conformity of the product with the CE Declaration of Conformity. The manufacturer is responsible for the conformity of the product with the CE Declaration of Conformity. The manufacturer is responsible for the conformity of the product with the CE Declaration of Conformity.

Approved by KreamControl  
 For an authorized signatory of the manufacturer  
 Signature: [Signature]  
 Name: [Name]  
 Title: [Title]

Approved by GTS  
 For an authorized signatory of the notified body  
 Signature: [Signature]  
 Name: [Name]  
 Title: [Title]

Verification No. CL100001011

**VERIFICATION OF LVD COMPLIANCE**

Applicant: KreamControl Electrical Equipment Co., Ltd.  
 Address of Applicant: No. 2 Building, Jiangping West Road (Jiangping West Road), Jiangping Street, Jiangping District, Jiangsu Province, Jiangsu, China.  
 Manufacturer: KreamControl Electrical Equipment Co., Ltd.  
 Product Description: Temperature and humidity transmitter, Temperature transmitter  
 Model No.: K3950, K3435

Substantive number of the product has been added and notified to be conforming with:  
 Test Standard: EN 61010-1:2010  
 As Annex to the:  
 Test Report No.: CL100001011  
 Date of Issue: August 2020  
 Date of Expiry: August 2023

The manufacturer of CE Declaration has been granted to sign based on the results of the conformity assessment of the product being notified. CE is a symbol of the administrative process conducted with the approval of the competent authority in the Member State. The CE Declaration is a statement of the manufacturer's responsibility for the conformity of the product with the CE Declaration of Conformity and is not a statement of the manufacturer's responsibility for the conformity of the product with the CE Declaration of Conformity. The manufacturer is responsible for the conformity of the product with the CE Declaration of Conformity. The manufacturer is responsible for the conformity of the product with the CE Declaration of Conformity. The manufacturer is responsible for the conformity of the product with the CE Declaration of Conformity.

Approved by KreamControl  
 For an authorized signatory of the manufacturer  
 Signature: [Signature]  
 Name: [Name]  
 Title: [Title]

Approved by GTS  
 For an authorized signatory of the notified body  
 Signature: [Signature]  
 Name: [Name]  
 Title: [Title]

Verification No. CL100001012

**VERIFICATION OF LVD COMPLIANCE**

Applicant: KreamControl Electrical Equipment Co., Ltd.  
 Address of Applicant: No. 2 Building, Jiangping West Road (Jiangping West Road), Jiangping Street, Jiangping District, Jiangsu Province, Jiangsu, China.  
 Manufacturer: KreamControl Electrical Equipment Co., Ltd.  
 Product Description: Temperature and humidity transmitter, Temperature transmitter  
 Model No.: K3950, K3435

Substantive number of the product has been added and notified to be conforming with:  
 Test Standard: EN 61010-1:2010  
 As Annex to the:  
 Test Report No.: CL100001012  
 Date of Issue: August 2020  
 Date of Expiry: August 2023

The manufacturer of CE Declaration has been granted to sign based on the results of the conformity assessment of the product being notified. CE is a symbol of the administrative process conducted with the approval of the competent authority in the Member State. The CE Declaration is a statement of the manufacturer's responsibility for the conformity of the product with the CE Declaration of Conformity and is not a statement of the manufacturer's responsibility for the conformity of the product with the CE Declaration of Conformity. The manufacturer is responsible for the conformity of the product with the CE Declaration of Conformity. The manufacturer is responsible for the conformity of the product with the CE Declaration of Conformity. The manufacturer is responsible for the conformity of the product with the CE Declaration of Conformity.

Approved by KreamControl  
 For an authorized signatory of the manufacturer  
 Signature: [Signature]  
 Name: [Name]  
 Title: [Title]

Approved by GTS  
 For an authorized signatory of the notified body  
 Signature: [Signature]  
 Name: [Name]  
 Title: [Title]

Verification No. CL100001013

**VERIFICATION OF LVD COMPLIANCE**

Applicant: KreamControl Electrical Equipment Co., Ltd.  
 Address of Applicant: No. 2 Building, Jiangping West Road (Jiangping West Road), Jiangping Street, Jiangping District, Jiangsu Province, Jiangsu, China.  
 Manufacturer: KreamControl Electrical Equipment Co., Ltd.  
 Product Description: Temperature and humidity transmitter, Temperature transmitter  
 Model No.: K3950, K3435

Substantive number of the product has been added and notified to be conforming with:  
 Test Standard: EN 61010-1:2010  
 As Annex to the:  
 Test Report No.: CL100001013  
 Date of Issue: August 2020  
 Date of Expiry: August 2023

The manufacturer of CE Declaration has been granted to sign based on the results of the conformity assessment of the product being notified. CE is a symbol of the administrative process conducted with the approval of the competent authority in the Member State. The CE Declaration is a statement of the manufacturer's responsibility for the conformity of the product with the CE Declaration of Conformity and is not a statement of the manufacturer's responsibility for the conformity of the product with the CE Declaration of Conformity. The manufacturer is responsible for the conformity of the product with the CE Declaration of Conformity. The manufacturer is responsible for the conformity of the product with the CE Declaration of Conformity. The manufacturer is responsible for the conformity of the product with the CE Declaration of Conformity.

Approved by KreamControl  
 For an authorized signatory of the manufacturer  
 Signature: [Signature]  
 Name: [Name]  
 Title: [Title]

Approved by GTS  
 For an authorized signatory of the notified body  
 Signature: [Signature]  
 Name: [Name]  
 Title: [Title]

Verification No. CL100001014

**VERIFICATION OF LVD COMPLIANCE**

Applicant: KreamControl Electrical Equipment Co., Ltd.  
 Address of Applicant: No. 2 Building, Jiangping West Road (Jiangping West Road), Jiangping Street, Jiangping District, Jiangsu Province, Jiangsu, China.  
 Manufacturer: KreamControl Electrical Equipment Co., Ltd.  
 Product Description: Temperature and humidity transmitter, Temperature transmitter  
 Model No.: K3950, K3435

Substantive number of the product has been added and notified to be conforming with:  
 Test Standard: EN 61010-1:2010  
 As Annex to the:  
 Test Report No.: CL100001014  
 Date of Issue: August 2020  
 Date of Expiry: August 2023

The manufacturer of CE Declaration has been granted to sign based on the results of the conformity assessment of the product being notified. CE is a symbol of the administrative process conducted with the approval of the competent authority in the Member State. The CE Declaration is a statement of the manufacturer's responsibility for the conformity of the product with the CE Declaration of Conformity and is not a statement of the manufacturer's responsibility for the conformity of the product with the CE Declaration of Conformity. The manufacturer is responsible for the conformity of the product with the CE Declaration of Conformity. The manufacturer is responsible for the conformity of the product with the CE Declaration of Conformity. The manufacturer is responsible for the conformity of the product with the CE Declaration of Conformity.

Approved by KreamControl  
 For an authorized signatory of the manufacturer  
 Signature: [Signature]  
 Name: [Name]  
 Title: [Title]

Approved by GTS  
 For an authorized signatory of the notified body  
 Signature: [Signature]  
 Name: [Name]  
 Title: [Title]

Verification No. CL100001015

**VERIFICATION OF LVD COMPLIANCE**

Applicant: KreamControl Electrical Equipment Co., Ltd.  
 Address of Applicant: No. 2 Building, Jiangping West Road (Jiangping West Road), Jiangping Street, Jiangping District, Jiangsu Province, Jiangsu, China.  
 Manufacturer: KreamControl Electrical Equipment Co., Ltd.  
 Product Description: Temperature and humidity transmitter, Temperature transmitter  
 Model No.: K3950, K3435

Substantive number of the product has been added and notified to be conforming with:  
 Test Standard: EN 61010-1:2010  
 As Annex to the:  
 Test Report No.: CL100001015  
 Date of Issue: August 2020  
 Date of Expiry: August 2023

The manufacturer of CE Declaration has been granted to sign based on the results of the conformity assessment of the product being notified. CE is a symbol of the administrative process conducted with the approval of the competent authority in the Member State. The CE Declaration is a statement of the manufacturer's responsibility for the conformity of the product with the CE Declaration of Conformity and is not a statement of the manufacturer's responsibility for the conformity of the product with the CE Declaration of Conformity. The manufacturer is responsible for the conformity of the product with the CE Declaration of Conformity. The manufacturer is responsible for the conformity of the product with the CE Declaration of Conformity. The manufacturer is responsible for the conformity of the product with the CE Declaration of Conformity.

Approved by KreamControl  
 For an authorized signatory of the manufacturer  
 Signature: [Signature]  
 Name: [Name]  
 Title: [Title]

Approved by GTS  
 For an authorized signatory of the notified body  
 Signature: [Signature]  
 Name: [Name]  
 Title: [Title]

Verification No. CL100001016

**VERIFICATION OF LVD COMPLIANCE**

Applicant: KreamControl Electrical Equipment Co., Ltd.  
 Address of Applicant: No. 2 Building, Jiangping West Road (Jiangping West Road), Jiangping Street, Jiangping District, Jiangsu Province, Jiangsu, China.  
 Manufacturer: KreamControl Electrical Equipment Co., Ltd.  
 Product Description: Temperature and humidity transmitter, Temperature transmitter  
 Model No.: K3950, K3435

Substantive number of the product has been added and notified to be conforming with:  
 Test Standard: EN 61010-1:2010  
 As Annex to the:  
 Test Report No.: CL100001016  
 Date of Issue: August 2020  
 Date of Expiry: August 2023

The manufacturer of CE Declaration has been granted to sign based on the results of the conformity assessment of the product being notified. CE is a symbol of the administrative process conducted with the approval of the competent authority in the Member State. The CE Declaration is a statement of the manufacturer's responsibility for the conformity of the product with the CE Declaration of Conformity and is not a statement of the manufacturer's responsibility for the conformity of the product with the CE Declaration of Conformity. The manufacturer is responsible for the conformity of the product with the CE Declaration of Conformity. The manufacturer is responsible for the conformity of the product with the CE Declaration of Conformity. The manufacturer is responsible for the conformity of the product with the CE Declaration of Conformity.

Approved by KreamControl  
 For an authorized signatory of the manufacturer  
 Signature: [Signature]  
 Name: [Name]  
 Title: [Title]

Approved by GTS  
 For an authorized signatory of the notified body  
 Signature: [Signature]  
 Name: [Name]  
 Title: [Title]

Verification No. CL100001017

**VERIFICATION OF LVD COMPLIANCE**

Applicant: KreamControl Electrical Equipment Co., Ltd.  
 Address of Applicant: No. 2 Building, Jiangping West Road (Jiangping West Road), Jiangping Street, Jiangping District, Jiangsu Province, Jiangsu, China.  
 Manufacturer: KreamControl Electrical Equipment Co., Ltd.  
 Product Description: Temperature and humidity transmitter, Temperature transmitter  
 Model No.: K3950, K3435

Substantive number of the product has been added and notified to be conforming with:  
 Test Standard: EN 61010-1:2010  
 As Annex to the:  
 Test Report No.: CL100001017  
 Date of Issue: August 2020  
 Date of Expiry: August 2023

The manufacturer of CE Declaration has been granted to sign based on the results of the conformity assessment of the product being notified. CE is a symbol of the administrative process conducted with the approval of the competent authority in the Member State. The CE Declaration is a statement of the manufacturer's responsibility for the conformity of the product with the CE Declaration of Conformity and is not a statement of the manufacturer's responsibility for the conformity of the product with the CE Declaration of Conformity. The manufacturer is responsible for the conformity of the product with the CE Declaration of Conformity. The manufacturer is responsible for the conformity of the product with the CE Declaration of Conformity. The manufacturer is responsible for the conformity of the product with the CE Declaration of Conformity.

Approved by KreamControl  
 For an authorized signatory of the manufacturer  
 Signature: [Signature]  
 Name: [Name]  
 Title: [Title]

Approved by GTS  
 For an authorized signatory of the notified body  
 Signature: [Signature]  
 Name: [Name]  
 Title: [Title]

Verification No. CL100001018

**VERIFICATION OF LVD COMPLIANCE**

Applicant: KreamControl Electrical Equipment Co., Ltd.  
 Address of Applicant: No. 2 Building, Jiangping West Road (Jiangping West Road), Jiangping Street, Jiangping District, Jiangsu Province, Jiangsu, China.  
 Manufacturer: KreamControl Electrical Equipment Co., Ltd.  
 Product Description: Temperature and humidity transmitter, Temperature transmitter  
 Model No.: K3950, K3435

Substantive number of the product has been added and notified to be conforming with:  
 Test Standard: EN 61010-1:2010  
 As Annex to the:  
 Test Report No.: CL100001018  
 Date of Issue: August 2020  
 Date of Expiry: August

# Temperature Resistance Table

## PT100 Resistance Value (Ω)

TEMP (°C)	0	-1	-2	-3	-4	-5	-6	-7	-8	-9
-40	84.27	83.87	83.48	83.08	82.69	82.29	81.89	81.5	81.1	80.7
-30	88.22	87.83	87.43	87.04	86.64	86.25	85.85	85.46	85.06	84.67
-20	92.16	91.77	91.37	90.98	90.59	90.19	89.8	89.4	89.01	88.62
-10	96.09	95.69	95.3	94.91	94.52	94.12	93.73	93.34	92.95	92.55
0	100	99.61	99.22	98.83	98.44	98.04	97.65	97.26	96.87	96.48
0	0	1	2	3	4	5	6	7	8	9
10	103.9	104.29	104.68	105.07	105.46	105.85	106.24	106.63	107.02	107.4
20	107.79	108.18	108.57	108.96	109.35	109.73	110.12	110.51	110.9	111.29
30	111.67	112.06	112.45	112.83	113.22	113.61	114	114.38	114.77	115.15
40	115.54	115.93	116.31	116.7	117.08	117.47	117.86	118.24	118.63	119.01
50	119.4	119.78	120.17	120.55	120.94	121.32	121.71	122.09	122.47	122.86
60	123.24	123.63	124.01	124.39	124.78	125.16	125.54	125.93	126.31	126.69
70	127.08	127.46	127.84	128.22	128.61	128.99	129.37	129.75	130.13	130.52
80	130.9	131.28	131.66	132.04	132.42	132.8	133.18	133.57	133.95	134.33
90	134.71	135.09	135.47	135.85	136.23	136.61	136.99	137.37	137.75	138.13
100	138.51	138.88	139.26	139.64	140.02	140.4	140.78	141.16	141.54	141.91
110	142.29	142.67	143.05	143.43	143.81	144.19	144.57	144.95	145.33	145.71
120	146.07	146.44	146.82	147.2	147.58	147.96	148.34	148.72	149.1	149.48
130	149.83	150.21	150.58	150.96	151.34	151.72	152.1	152.48	152.86	153.24
140	153.58	153.96	154.34	154.72	155.1	155.48	155.86	156.24	156.62	157
150	157.33	157.71	158.09	158.47	158.85	159.23	159.61	160	160.38	160.76
160	161.05	161.43	161.81	162.19	162.57	162.95	163.33	163.71	164.09	164.47
170	164.77	165.15	165.53	165.91	166.29	166.67	167.05	167.43	167.81	168.19
180	168.48	168.86	169.24	169.62	170	170.38	170.76	171.14	171.52	171.9
190	172.17	172.55	172.93	173.31	173.69	174.07	174.45	174.83	175.21	175.59
200	175.86	176.24	176.62	177	177.38	177.76	178.14	178.52	178.9	179.28

## NTC1K B3950 Resistance Value (Ω)

TEMP (°C)	0	-1	-2	-3	-4	-5	-6	-7	-8	-9
-30	18.8125	20.0726	21.4278	22.8863	24.4567	26.1486	27.9724	29.9395	32.0623	34.3545
-20	10.1015	10.7273	11.3969	12.1137	12.8816	13.7045	14.5869	15.5334	16.5494	17.6403
-10	5.6702	5.9961	6.3433	6.7134	7.1079	7.5287	7.9778	8.4572	8.9693	9.5165
0	3.3112	3.4884	3.6764	3.876	4.0878	4.3128	4.552	4.8061	5.0765	5.3641
0	0	1	2	3	4	5	6	7	8	9
10	3.3112	3.1441	2.9865	2.8378	2.6974	2.5648	2.4396	2.3212	2.2094	2.1035
20	2.0034	1.9087	1.819	1.7341	1.6537	1.5774	1.5052	1.4367	1.3717	1.31
30	1.2515	1.1959	1.1431	1.093	1.0453	1	0.9569	0.916	0.877	0.8399
40	0.8046	0.7709	0.7389	0.7084	0.6793	0.6516	0.6251	0.5999	0.5758	0.5529
50	0.5309	0.51	0.49	0.4709	0.4527	0.4352	0.4185	0.4026	0.3873	0.3727
60	0.3588	0.3454	0.3326	0.3204	0.3086	0.2974	0.2866	0.2763	0.2664	0.2569
70	0.2478	0.239	0.2306	0.2226	0.2149	0.2074	0.2003	0.1935	0.1869	0.1806
80	0.1745	0.1687	0.1631	0.1577	0.1525	0.1475	0.1427	0.1381	0.1336	0.1293
90	0.1252	0.1212	0.1174	0.1137	0.1101	0.1067	0.1034	0.1002	0.0971	0.0942
100	0.0913	0.0886	0.0859	0.0833	0.0808	0.0785	0.0761	0.0739	0.0717	0.0697
110	0.0677	0.0657	0.0638	0.062	0.0602	0.0585	0.0569	0.0553	0.0538	0.0523
120	0.0508	0.0494	0.0481	0.0468	0.0455	0.0443	0.0431	0.042	0.0408	0.0398
130	0.0387	0.0377	0.0367	0.0358	0.0348	0.0339	0.0331	0.0322	0.0314	0.0306
140	0.0298	0.0291	0.0284	0.0277	0.027	0.0263	0.0257	0.0251	0.0244	0.0239
150	0.0233	0.0227	0.0222	0.0216	0.0211	0.0206	0.0202	0.0197	0.0192	0.0188
160	0.0183	0.0179	0.0175	0.0171	0.0167	0.0164	0.016	0.0156	0.0153	0.0149
170	0.0146	0.0143	0.014	0.0137	0.0134	0.0131	0.0128	0.0125	0.0123	0.012
180	0.0117	0.0115	0.0113	0.0111	0.0108	0.0106	0.0103	0.0101	0.0099	0.0097
190	0.0095	0.0093	0.0091	0.0089	0.0088	0.0086	0.0084	0.0083	0.0081	0.0079
200	0.0078	0.0076	0.0075	0.0073	0.0072	0.0071	0.0069	0.0068	0.0067	0.0065

## PT1000 Resistance Value (Ω)

TEMP (°C)	0	-1	-2	-3	-4	-5	-6	-7	-8	-9
-40	842.7	838.7	834.8	830.8	826.9	822.9	818.9	815	811	807
-30	882.2	878.3	874.3	870.4	866.4	862.5	858.5	854.6	850.6	846.7
-20	921.6	917.7	913.7	909.8	905.9	901.9	898	894	890.1	886.2
-10	960.9	956.9	953	949.1	945.2	941.2	937.3	933.4	929.5	925.5
0	1000	996.1	992.2	988.3	984.4	980.4	976.5	972.6	968.7	964.8
0	0	1	2	3	4	5	6	7	8	9
10	1000	1003.9	1007.8	1011.7	1015.6	1019.5	1023.4	1027.3	1031.2	1035.1
20	1039	1042.9	1046.8	1050.7	1054.6	1058.5	1062.4	1066.3	1070.2	1074
30	1077.9	1081.8	1085.7	1089.6	1093.5	1097.3	1101.2	1105.1	1109	1112.9
40	1116.7	1120.6	1124.5	1128.3	1132.2	1136.1	1140	1143.8	1147.7	1151.5
50	1155.4	1159.3	1163.1	1167	1170.8	1174.7	1178.6	1182.4	1186.3	1190.1
60	1194	1197.8	1201.7	1205.5	1209.4	1213.2	1217.1	1220.9	1224.7	1228.6
70	1232.4	1236.3	1240.1	1243.9	1247.8	1251.6	1255.4	1259.3	1263.1	1266.9
80	1270.8	1274.6	1278.4	1282.2	1286.1	1289.9	1293.7	1297.5	1301.3	1305.2
90	1309	1312.8	1316.6	1320.4	1324.2	1328	1331.8	1335.7	1339.5	1343.3
100	1347.1	1350.9	1354.7	1358.5	1362.3	1366.1	1369.9	1373.7	1377.5	1381.3
110	1385.1	1388.8	1392.6	1396.4	1400.2	1404	1407.8	1411.6	1415.4	1419.1
120	1422.9	1426.7	1430.5	1434.3	1438	1441.8	1445.6	1449.4	1453.1	1456.9
130	1460.7	1464.4	1468.2	1472	1475.7	1479.5	1483.3	1487	1490.8	1494.6
140	1498.3	1502.1	1505.8	1509.6	1513.3	1517.1	1520.8	1524.6	1528.3	1532.1
150	1535.8	1539.6	1543.3	1547.1	1550.8	1554.6	1558.3	1562	1565.8	1569.5
160	1573.3	1577	1580.7	1584.5	1588.2	1591.9	1595.6	1599.4	1603.1	1606.8
170	1610.5	1614.3	1618	1621.7	1625.4	1629.1	1632.9	1636.6	1640.3	1644
180	1647.7	1651.4	1655.1	1658.9	1662.6	1666.3	1670	1673.7	1677.4	1681.1
190	1684.8	1688.5	1692.2	1695.9	1699.6	1703.3	1707	1710.7	1714.3	1718
200	1721.7	1725.4	1729.1	1732.8	1736.5	1740.2	1743.8	1747.5	1751.2	1754.9
210	1758.6	1762.2	1765.9	1769.6	1773.3	1776.9	1780.6	1784.3	1787.9	1791.6

## NTC2K B3950 Resistance Value (Ω)

TEMP (°C)	0	-1	-2	-3	-4	-5	-6	-7	-8	-9
-10	11.1525	11.7831	12.4541	13.1682	13.9285	14.7385	15.6015	16.5216	17.5029	18.55
0	6.5613	6.908	7.2755	7.6652	8.0785	8.517	8.9824	9.4766	10.0016	10.5594
0	0	1	2	3	4	5	6	7	8	9
10	6.5613	6.234	5.9249	5.6331	5.3573	5.0966	4.8502	4.6171	4.3966	4.1878
20	3.9902	3.8031	3.6258	3.4578	3.2985	3.1475	3.0042	2.8683	2.7393	2.6168
30	2.5005	2.39	2.285	2.1851	2.0903	2	1.9141	1.8324	1.7547	1.6806
40	1.6101	1.5429	1.4789	1.4179	1.3597	1.3043	1.2514	1.2009	1.1527	1.1067
50	1.0628	1.0209	0.9808	0.9425	0.9059	0.8709	0.8375	0.8055	0.7749	0.7456
60	0.7176	0.6908	0.6651	0.6405	0.6169	0.5944	0.5727	0.552	0.5321	0.513
70	0.4947	0.4772	0.4603	0.4442	0.4287	0.4138	0.3995	0.3857	0.3725	0.3599
80	0.3477	0.336	0.3247	0.3139	0.3034	0.2934	0.2838	0.2745	0.2656	0.257
90	0.2487	0.2407	0.233	0.2256	0.2185	0.2116	0.205	0.1986	0.1925	0.1866
100	0.1808	0.1753	0.17	0.1648	0.1599	0.1551	0.1505	0.146	0.1417	0.1375
110	0.1335	0.1296	0.1259	0.1222	0.1187	0.1153	0.1121	0.1089	0.1058	0.1029
120	0.1	0.0972	0.0945	0.0919	0.0894	0.087	0.0846	0.0823	0.0801	0.078
130	0.0759	0.0739	0.0719	0.07	0.0682	0.0664	0.0647	0.063	0.0614	0.0598
140	0.0583	0.0568	0.0554	0.054	0.0526	0.0513	0.0501	0.0488	0.0476	0.0463
150	0.0453	0.0442	0.0432	0.0421	0.0411	0.0401	0.0392	0.0383	0.0374	0.0365